

## **8 WASTEWATER**

### **8.1 Introduction**

The purpose of this section is to outline Council's requirements for the provision of wastewater reticulation.

It is important that wastewater disposal matters are adequately addressed within all developments, regardless of size and scale. The standards in this section provide a basis for the design and construction of a reticulated wastewater system, to dispose of wastewater in a Council-provided treatment facility.

#### **8.1.1 Objectives**

The following objectives must be met in the provision of any wastewater disposal reticulation:

- a) The health and safety of people and communities is ensured;
- b) The system is cost-effective and efficient in serving communities over the long- term;
- c) The standard of materials is durable and robust to ensure a long design life and minimise the need for ongoing maintenance and repair;
- d) The design and layout of the proposed system will minimise the potential for system failure or damage and avoid the risk of blockages, odours and overflows (overflows will occur and these shall be designed to overflow in suitably managed locations ideally from manholes then gully traps 300 mm below floor level);
- e) The location and alignment of all wastewater pipes will enable easy access for maintenance and repair works with a minimum of disruption to other services, and
- f) Ownership and maintenance responsibilities of all and any privately-owned parts of the wastewater system are clearly defined;

#### **8.1.2 Key References**

Table 8-1 sets out the New Zealand, Australian and British Standards and publications that apply to the design and construction of wastewater systems except where modified by current Tasman District Council Engineering Standards and Policies.

**Table 8-1: Standards\* Related to the Design and Construction of Wastewater Services**

<b>Standards and Publications Related to the Design and Construction of Wastewater Services</b>	
AS/NZS1260:2009	PVC-U Pipes and fittings for drain, waste and vent application
AS/NZS2032	Installation of PVC pipe systems
AS/NZS2566.1	Buried flexible pipelines – Structural design
AS/NZS4058	Pre-cast concrete drainage pipes (pressure and non-pressure)
NZS3109	Concrete construction
NZS3121	Specification for water and aggregate for concrete
BS3412	PE materials for moulding and extrusion
AS3572	Glass filament reinforced plastics
AS3996:2006	Manhole covers
AS/NZS3725	Design for installation of buried concrete pipes
NZS4442	Welded steel pipes and fittings for water, sewage, and medium pressure gas
NZS7643	Code of practice for the installation of unplasticized PVC pipe systems
	Building Act 2004
	New Zealand Pipe Inspection Manual 3 <sup>rd</sup> edition
* The current version of the standard is to be used.	

## **8.2 Reticulation Design**

### **8.2.1 General**

The following general matters apply to the design of wastewater reticulation:

- a) Wastewater disposal shall be provided to every allotment by means of a connection to a reticulated wastewater system wherever possible and within urban drainage areas.
- b) All systems shall be designed to accommodate the flow from upstream of the subdivision or development and shall be of sufficient capacity to provide for maximum flow from possible future development.
- c) The Designer shall minimise retention of wastewater in piped systems and potential for wastewater to become anaerobic and produce gases by:
  - i making use of adequate grades for self cleansing and slime control;
  - ii avoiding use of wastewater pumping stations where possible;
  - iii ensuring adequate ventilation of stale wastewater; and
  - iv avoiding any unnecessary turbulence at junctions and changes in grades, particularly where rising mains enter gravity system at drop junctions.
- d) Increased use of an existing wastewater sewer may require upgrading of a downstream network to prevent overloading. This may require investigation and redesign of that system and subsequent approval for its upgrade by Council.

- e) Under no circumstances shall a wastewater sewer be connected to a stormwater drain.
- f) A main wastewater sewer shall be provided for the full length of each new road/street, unless approved otherwise by Council. Pipes shall be extended past the far boundary of the development by a distance equivalent to the depth to invert and be capped off.
- g) Ventilation of pipelines/manholes may be required.
- h) To be classified as a public wastewater sewer, a pipeline must have been inspected ie, CCTV, approved, and designated as such by Council. Council responsibility does not extend to private pumping systems and rising mains, which remain the responsibility of the users they serve.

### **8.2.2 Private connections**

- a) In all new subdivisions, a 100mm diameter wastewater drain shall be provided at least 1.0m inside the boundary of every lot or body of each lot (ie, served by ROW) with an access point installed on the road side of the boundary or before it connects to the private sewer. The maximum depth of the access point shall be 900mm. Wastewater laterals, pipes and end caps shall be painted red, (stormwater shall be painted green). See TDC Drawing 807 for the LHCE lateral inspection point at the boundary. Pipe ends staked – See Section 7.7.3(a).
- b) In commercial and industrial subdivisions where there is a wastewater sewer in the road fronting the subdivision, the lateral service connections shall be 150mm diameter installed to the back of kerb or 1.0m beyond the edge of seal. Laterals may be omitted beyond this point until the specific requirements of the consumer are known. A mini-manhole or similar will be required at building consent stage, either as shown on TDC Drawing 803 or an approved prefabricated design.
- c) Pipes shall be deep enough to provide gravity service and be installed to the boundary of the adjacent property.
- d) Each connection shall be adequate to serve the section and to have a self-cleansing velocity flowing full.
- e) To minimise the potential for a wastewater overflow into private property, the minimum lid level of any gully trap for all new dwellings shall not be less than 150mm above the lid level of the manhole on the public wastewater sewer immediately upstream of the lateral connection. The only exception to this requirement would be on hillsides or sloping land where compliance is not practical.
- f) In some locations a gravity connection to the wastewater sewer may not be possible and the discharge may have to be pumped to the wastewater system. This will require specific design and approval via a building consent.

### **8.2.3 Trade waste**

- a) The discharge of trade waste into a wastewater sewer is subject to the current TDC Trade Waste Bylaw.

- b) Contaminated stormwater effluent that contains a combination of detergent and/or degreasing agents with oil and/or silt shall be directed to the wastewater sewer after first passing through a silt and oil trap built to TDC Drawing 801 standard.
- c) Any proposal to discharge contaminated stormwater to the wastewater network shall require a Trade Waste application and comply with the provisions set out in the TRMP.
- d) Building consents are required for all works together with a monitoring programme.
- e) For premises where food is prepared, a minimum of an under bench style oil trap shall be provided, subject to the design and annual maintenance check being submitted to Council.
- f) To ensure stormwater does not enter the wastewater system any area being served by the silt and oil trap must be roofed and have a low bund around the perimeter with a minimum height of at least 50mm, see TDC Drawing 801.

#### 8.2.4 Alternative treatment and disposal systems

- a) Decentralised treatment systems (or similar) may be considered but would require specific design and approval of the Engineering Manager.
- b) Pressurised small bore systems (or similar) may be considered (for commercial and Industrial zoned land only) but would require specific design and approval of the Engineering Manager.

### 8.3 Pipe Design

**Table 8-2: Minimum specification for public wastewater pipes**

	<b>Concrete pipe</b>	<b>uPVC pipe</b>
Permitted size	Minimum 375mm ID	Minimum 150mm ID
Minimum standard	NZS3107	AS/NZS1260
Material strength	Minimum Class 2 and in accordance with AS/NZS3725	Minimum SN 8 Specific design to AS/NZS2566 method for depth >5.0m, or traffic wheel loads >96 kN
Cover depth	Refer Table 7-8	Refer Table 7-8
Joints	Rubber ring jointed	
Pipe capacity	As per Section 8.3.1	
Flow velocity	As per Table 8-4	
Pipe location (in preference)	Road reserve Note TDC Drawing 700	
Clearance from other services	Minimum 200mm vertical Minimum 500mm horizontal	

#### 8.3.1 Calculation of Flow

The following matters should be taken into account in determining the capacity of the system:

- a) The catchment area is defined as the total gravity catchment upstream of the point being considered.
- b) Several trunk gravity sewers discharging into one pump station shall be considered as separate catchments.
- c) Discharge rates from pump stations may be accumulated but their catchment areas shall not.

Industrial and commercial areas shall be treated as residential unless a greater rate of discharge is known.

## 8.4 Material Specifications

### 8.4.1 Pipe Material

The following specifications apply to all pipe work that makes up Council's wastewater reticulation:

- a) Wastewater sewers shall generally be rubber ring jointed PVC pipes and fittings complying with AS/NZS1260 and laid in 6.0m lengths. Pipe stiffness shall be in accordance with Table 8-3.
- b) PE (polyethylene) pipe complying with AS/NZS4130 may be used in specific circumstances (eg, for sleeving or relining existing wastewater sewers and in wastewater rising mains) with the approval of the Engineering Manager.

**Table 8-3: Pipe Stiffness Required for uPVC Pipe**

uPVC Pipe	Public Wastewater Sewers	Private Wastewater Sewers
DN 100mm	SN 10	SN 6
DN 150mm	SN 8	SN 4
DN 175mm and larger	SN 4	SN 4
depths greater than 5.0m	Specific design to AS/NZS2566 design method	
wheel loads > 96 kN	Specific design to AS/NZS2566 design method	

### 8.4.2 Pipe Size

The minimum permissible diameter for all new public wastewater sewers is 150mm except as detailed below.

- a) When an infill subdivision development (hereinafter referred to as infill development) occurs in an area serviced by an existing 100mm diameter public wastewater sewer it need not be upgraded to 150mm subject to Council approval provided that:
  - i. the existing sewer is not located longitudinally in the road reserve;
  - ii. the existing pipe material is uPVC;
  - iii. the existing sewer will service 5 or less residential units in total; and
  - iv. the installation complies with the current Engineering Standards and Policies.
- b) Where a 100mm diameter public wastewater sewer will be upgraded to 150mm diameter an Engineering Drawing including the longitudinal section shall be provided together with as built plans of the completed works.
- c) Where infill development results in an existing 150mm uPVC private drain becoming public sewer, the existing pipe shall be:

- i pressure tested to prove that it is sound, and
  - ii tested for roundness with an appropriate gauging tool, and
  - iii CCTV inspected to prove that it is sound;
  - iv other appropriate test will be considered but if found to be unsuitable the pipe shall be re-laid.
- d) When vesting a private sewer as a public wastewater sewer, surface opening manholes or alternatives shall be provided in compliance with the Engineering Standards for new wastewater sewers.
- e) The following classes shall apply:
- i DN 100mm diameter shall be minimum stiffness class SN 10 for public sewers and SN 6 for private sewers.
  - ii DN 150mm diameter shall be minimum stiffness class SN 8 for public sewers and SN 4 for private sewers.
  - iii DN 175mm and larger shall be minimum stiffness class SN 4 for public and private sewers.
  - iv Specific design shall apply for depths greater than 5.0m, or traffic wheel loads greater than 96 kN, using AS/NZS2566 design method.
- f) All wastewater sewers shall be designed to utilise velocity and flow characteristics to improve hydraulic performance and minimise settlement of solids and future maintenance costs.
- g) Wastewater sewers shall generally be no deeper than 2.5m below finished ground levels. Where sewers are required at a depth greater than 2.5m, design calculations and manufacturers specifications shall be provided to show that the proposed pipeline will withstand the additional loading imposed by the depth of cover without deformation or damage.
- h) Domestic flows shall be calculated on the basis of the average dry weather flow of 210 litres per person per day. Peak wet weather flow shall be calculated as six times the average dry weather flow. Commercial and industrial areas will need specific design depending on the type of trade waste or likely discharge for that area.
- i) The same roughness factor shall be adopted for all pipe materials to account for sewer slimes, grit deposits and other *in situ* variables such as construction performance and pipeline deterioration with age.
- j) To prevent pipe blockages the minimum size of the public connection shall be one size bigger than the private connection they connect to. Downstream pipe sizes within a public system shall not decrease in pipe size to prevent potential pipe blockages.

**Table 8-4: Minimum Velocity and Grade Requirements**

Internal Diameter	Residential Units Served	Minimum Grade	Minimum Velocity Flowing Full
150mm	1–5	1.25% - 1-in-80	1.0m/s
150mm	6–10	1.00% - 1-in-100	0.9m/s
150mm	11–19	0.80% - 1-in-125	0.8m/s
150mm	20–150	0.67% - 1-in-150	0.75m/s
>150mm	Specific design	Specific design	0.75m/s

- a) The above are indicative only and specific design will be required on submission of the design plans.
- b) Where velocity limits cannot be complied with, additional works may be required in order to obtain satisfactory operation of the system.
- c) The recommended minimum grade for a 100mm wastewater sewer is 1-in-60, which allows for improved hydraulics and minimises future maintenance cost on the line. Note: a building consent is required for 100mm diameter sewer laterals.

### 8.4.3 Manholes

These standards and conditions apply to the design and material specifications for manholes:

- a) Manholes are to be located in the road carriageway, preferably at the centreline of the road but no closer than 2.0m to kerb and channel, to minimise inflow from stormwater flowing down the road/street. Manholes maybe permitted on the grass berm or footpath provided that the fall is towards the road kerb and channel.
- b) Manholes will be required in the following locations:
  - At maximum centres of 100m;
  - At change of direction;
  - At change of grade;
  - At change of pipe diameter;
  - At junctions of main drains;
  - At the head of a main drain, and
  - As required to keep within the road carriageway.
- (c) Manholes shall conform to TDC Drawings 802 to 806 unless other detailed drawings are approved by Council. Consideration will be given to prefabricated manholes and pipes which will inhibit the infiltration of stormwater.
- (d) Shallow mini-manholes shall be in accordance with the requirements set out on TDC Drawing 803 or a proprietary PVC or polypropylene moulded product approved by Council.
- (e) The diameter of any manhole installed shall meet the dimensional requirements set out in TDC Drawing 716. These are:
  - A fall of no less than 50mm shall be provided through all manholes.
  - All pipes shall be matched to soffits of the enlarged outgoing pipes.

- (f) Council will accept fully sealable locking and hinged manholes that comply with NZS3996. The hinged manhole shall be laid with the lid folding flat in the direction of traffic flow.

## **8.5 Pumping Stations**

### **8.5.1 Pump station design**

- a) In the design of pumping stations early consultation with the Engineering Manager is essential.
- b) Design of wastewater pumping stations shall enable operation of the station in compliance with industry health and safety requirements.
- c) Pumping stations shall be of the wet-well type, fitted with approved types of submersible pumps (FLYGT and PUMPEX are the preferred makes, however other makes may be considered). Other designs will be considered by the Engineering Manager.
- d) Pump stations shall comply with TDC requirements and these specific designs are updated on a regular basis. Design will be dependent on a number of factors and should be discussed with the Engineering Manager at an early stage.
- e) Pumping stations are to be located where occasional adverse effects of smell and/or noise will have minimum impact, ie, reserve/drainage areas and not within 20m of a residential dwelling. New pump stations will only be accepted by Council when all other practical options have been exhausted. (Filling of sites is a normal practical option to gain the required gravity fall). Pump stations shall not be located in low-lying areas with potential to be subjected to surface flooding.
- f) In all pumping stations the following design specifications apply:
  - i. Sufficient duty pumping capacity is installed to handle the design peak flow rate.
  - ii. A minimum of two pumps on guide rails with lifting chains shall be installed, with one acting as duty pump and the other on automatic standby. The duty sequence is to be interchangeable. The standby pump shall be equal in capacity to the duty pump.
  - iii. The wet well shall be of sufficient volume and shape so as to limit the frequency of pump starts, allow cooling of pumps and to minimise potential odours. The dimensions of the wet-well shall be such that under maximum flow conditions the number of starts for the pumps shall not exceed the pump manufacturer's recommendations.
  - iv. A minimum of six hours on-site emergency storage, not including reticulation storage shall be provided based on the average dry weather flow measured between the overflow and first high level alarm level (ie start level with delay) (measured by Multitrode). The six-hour storage shall be self draining, easily cleaned and shall normally be located in an underground approved structure and covered with topsoil or approved alternative.
  - v. Where it will be located within 100.0m of any stream, body of water and/or within 200m of a Recreation Zone, Open Space Zone or Conservation Zone, the minimum emergency storage capacity shall be increased to 10 hours, and/or when it is located more than one hour's normal driving time from either Richmond CBD or Takaka CBD.



- g) Wet wells and, when approved, dry wells, may be provided with proper ventilation. An approved odour control filtration bed with irrigation facilities as necessary, and an extractor fan, shall be constructed adjacent to the pump station to mitigate odours. Other odour control devices may be approved on a case-by-case basis.
- h) Ground floor levels and slab levels of underground structures shall be at least 200mm above finished ground levels in order to exclude surface water and be made water resistant. Flood levels to be specifically assessed.

### **8.5.2 Access and services**

- a) A 20mm diameter water supply with a standard 15mm brass hose tap must be provided in the immediate vicinity of the pump station. Supply shall be fitted with an approved testable (reduced pressure zone RPZ) backflow preventer and water meter.
- b) Pumping stations shall be sited on a separate lot or a drainage or utility reserve. The lot is to be vested in Council and shall have all-weather access, adequate landscaping and fencing (as required, and at Council's discretion). Pumping stations on road reserves will not generally be accepted due to OSH requirements and disruption to the travelling public.
- c) A means of lifting pumps and other heavy equipment, or alternatively access to enable mobile plant to perform this task is to be provided.
- d) An approved flow meter shall be installed on the outlet line from the pump station and connected to the telemetry system.

### **8.5.3 Electrical Equipment**

An electrical pump control, alarm, and telemetry system is required on site. It shall be assembled and installed in accordance with Council's standard specification, as follows:

- a) A stainless steel (normally dark green or beige) approved by the Engineering Manager and built to Council specifications is required to house electrical equipment. Cabinets are to be fitted with an Abloy security lock keyed to Council's security system as instructed by the Engineering Manager.
- b) Cabinets shall comply with health and safety requirements which will include secure door stays and could include shelter to the utility operator in inclement weather. Cabinet and controls etc shall be protected from corrosive gasses and vermin proof. Glass reinforced plastic (GRP) cabinets will not be accepted.
- c) All electrical switch gear is to be located above ground level to the satisfaction of the Engineering Manager incorporating a "Technical Specification-Sewer Pump Station Electrical works". All electrical equipment is to be assembled and installed in accordance with these standards or the manufacturer's specifications.
- d) All equipment must comply with the requirements of the Network Utility Operator (power).
- e) Suitable alarm interrogation and transmitting facilities shall be provided to enable the pumping stations to be connected to Council's telemetry system.

- f) Cable ducting from the pump station to the control cabinet must be sealed to protect against corrosive gases travelling to the electrical switchboard.
- g) Single-phase protection to all pump motors is to be provided.
- h) Automatic control of the pump operation, together with a manual override facility is to be provided.
- i) A standard industrial power connection shall be supplied such that a portable generator can be connected when power failure occurs.
- j) Suitable lighting shall be provided for the pump station, cabinets and valve chambers and protected from the corrosive environment.
- k) Details on pump/motor components and electrical control equipment shall be incorporated into an Operation and Maintenance Instruction Manual enclosed in a hard copy A4 bound folder.
- l) The folder shall include as-built plans of the pump station including electrical wiring and operational schematic diagrams. Four copies of the Operations and Maintenance Instruction Manual shall be supplied to Council on handover of the completed pump station and associated works.

#### **8.5.4 Wastewater Rising Mains**

Wastewater rising mains shall meet the requirements for the construction of water mains, except that the testing requirements shall require the rising main to withstand the greater of a pressure of 900kpa or 1.5 times the working pressure of the system. Designs shall take into account Cyclic Dynamic Stresses (Fatigue) in accordance with design guides.

#### **8.5.5 Commissioning**

On completion of any pump station, and prior to handover to Council, a full commissioning test shall be carried out on all components of the pump station. This commissioning shall be in the presence of a representative of Council and of Council's operations and maintenance contractor.

### **8.6 Construction and Installation**

#### **8.6.1 Excavation Works**

The following standards and conditions apply to the excavation in preparation for pipework laying:

- a) All drainage pipelines shall be constructed in accordance with the requirements of NZS7643. All works undertaken on Council sewers shall be undertaken by trained personnel as specified in section 3. A wastewater connection application is to be submitted to Council prior to approval and works commencing (Appendix 8-1).
- b) The maximum width of unshielded trench, measured at the level of the top of the pipe shall not exceed a dimension equal to the external diameter of the pipe plus 300mm.
- c) Excavation of manholes shall be only of sufficient size to leave adequate space for construction and for compaction of backfill.

- d) Excavations shall be kept free of water during construction.
- e) In no circumstances shall stormwater or groundwater be allowed to drain into any existing sewer, and pipe ends shall be plugged to prevent such ingress.
- f) Discharge of stormwater or groundwater to existing stormwater drains or the stormwater pipes already laid will be permitted providing adequate silt traps prevent debris and suspended matter from entering drains.
- g) Should deposits in existing stormwater drains or the pipes already laid occur as a result of the operations of the landowner or the contractor, such deposits shall be cleared forthwith at the landowner's or the contractor's cost as the case may be.
- h) Groundwater lowering may be permitted except where this practice may present a risk of subsidence.
- i) The contractor or landowner shall cause as little damage or interference to property or persons as possible in disposing of water from the works and shall be responsible for any damage or interference which may be caused. This shall include any damage to the structure of any road. Any dewatering operation must comply with the relevant sections of the TRMP and resource consents gained where applicable.

### **8.6.2 Laying and Jointing**

These standards apply to the laying of pipes:

- a) The end caps and inside of the end of all new wastewater sewer laterals (after the mini-manhole) must be painted with red acrylic paint to help with future identification. (Note: stormwater laterals are to be marked green).
- b) The actual work of laying pipes shall be done by a registered drainlayer approved by Council and meets the appropriate Health and Safety requirements..
- c) A laser shall be used by the contractor for fixing line and grade, for setting the pipes to line and level and for jointing on all major pipe-laying work where possible. Sight boards and boning rods will only be approved on minor works, eg, infill subdivisions, or on steep gradients.
- d) The deviation from design level of the pipe invert when laid shall be no greater than 20mm. The horizontal deviation from a straight line between manholes shall be no greater than 50mm. Note this requirement only relates to pipe grades up to 1-in-150 or steeper.
- e) Pipes shall not be laid on bricks, blocks and wedges or other temporary or permanent supports except when concrete surround is to be placed.
- f) Joints shall be flexible and water tight.
- g) Pipes shall be kept clear of dirt, or debris, and any pipes that contain such matter shall be required to be cleaned out. The ends of pipelines are to be temporarily capped at the end of each day's work to prevent animals or foreign matter entering the pipe.

### 8.6.3 Manhole Installation

The following standards apply to manholes and the installation of them:

- a) For minimum cover requirements refer to Section 7.8.
- b) Manholes shall be constructed in accordance with TDC Drawings 802 and 803.
- c) All manholes shall be made water tight by effective sealing of manhole section joints with mastic sealant and around pipe entries, where applicable, using epoxy mortar inside and out.
- d) Manholes must be designed to resist uplift especially in areas where high ground water is experienced. One piece manholes (riser and base) are preferred to minimise infiltration.
- e) All PVC pipes entering or leaving a manhole shall have one flexible joint within 200mm of the manhole and a second flexible joint within 1200mm of the manhole.
- f) The channel through the manhole shall be formed from *in-situ* concrete / ceramic properly formed to grade and radius sweeps. The channel shall be finished with a smooth, regular half circle invert with falls as specified in TDC Drawing 802. Benching shall be steel float finished to give a regular smooth surface.
- g) All manholes shall be tested for water tightness on completion by plugging all entry/exit pipes, and filling the manhole with water to the underside of the cast iron lid ring.  
A period of ten (10) minutes shall be allowed for absorption of water into the concrete and the water level shall be restored prior to commencement of the test. No water level drop is permitted over 10 minutes.
- h) If manhole cover slabs other than “Humes” or “Hynds” pre-cast concrete cover slabs are to be used then the appropriate certification must be submitted to Council showing that the cover slabs will withstand loadings of 0.85HN (51kN).
- i) The opening, picton ring and cover of a manhole (other than a mini-manhole) shall have a minimum diameter of 600mm. Heavy duty cast iron manhole lids are to be used in all road carriageways and in areas where lighter lids are prone to be dislodged.

### 8.6.4 Pumping/Pressure Main Tracer Tape

All wastewater mains are to be marked in the following manner:

- a) The location of all pumping or pressure mains shall be marked with an approved foil or wire banded tape, buried in the trench.
- b) The tape shall be of 75mm wide or 50mm wide with acid and alkali resistant polythene plastic with a solid aluminium foil or wire core which shall be visible from both sides and coloured **red** or **orange**.
- c) The foil shall be continuously printed in red “caution wastewater pumping/pressure sewer main buried below” with no ink or printing extending to the edges of the tape. All printing shall be encased to avoid ink rub off.

- d) The adhesives that bond the protective plastic jacket to both sides of the foil or wire shall be applied directly to the film and foil layers to provide a continuous metallic seal.
- e) The tape shall be buried above the centre line of the pipe within 300mm to 400mm from the finished surface.
- f) All joints in the tape (eg, roll ends, accidental breaks and at tees) shall be made electrically conductive with purpose-made splice clips installed to the specific manufacturer's instructions. Tying together of the tape ends is not acceptable as the polythene coating will prevent electrical conductivity.
- g) The tape shall be brought up inside surface box risers at all air valves with a 300mm long tail so that pipe location equipment can be readily connected.
- h) When a pumping or pressure pipe is installed by a directional drilling technique or bored through the ground, the pipe shall have a "tracer wire" attached. This wire shall take the form of a continuous 2.5mm<sup>2</sup> multi-strand (polythene sleeved) cable, strapped to the pipe wall by means of a minimum of two complete wraps of heavy duty adhesive tape, at a maximum of 3.0m intervals.

#### **8.6.5 Connection to Council network**

Connection to existing wastewater mains shall not be made until all upstream work has been completed and inspected and approved by Council. Specifically, this shall include flushing and testing of all new pipework, manholes, and other wastewater facilities by the contractor and internal (CCTV) and external inspections by Council.

No contractor is permitted to enter a live wastewater system without the approval of the Engineering Manager and Council's current Operations and Maintenance Contractor.

- a) Connection to existing Council wastewater systems shall be made only by Council's current Operations and Maintenance Contractor or by a contractor approved by Council.
- b) Contractors authorised to make connections shall have written authorisation from Council and be recorded on a Register of Approved Contractors for work on wastewater systems. An approved contractor will demonstrate to the satisfaction of the Engineering Manager that staff have appropriate training, and the company operates robust quality plans and health and safety plans to adequately protect the staff engaged in such work as well as Council's asset.
- c) Where connection is to be made to an existing manhole it shall be carried out in accordance with the relevant detail contained in Drawings 802 to 806.
- d) Where connection is made by constructing a new manhole on an existing wastewater sewer it shall be constructed by Council's current Operations and Maintenance Contractor or by a contractor approved by Council. The manhole shall be constructed with appropriate starters and haunching prior to installation. Installation shall be on a level, well compacted gravel base and connection, including specified flexible joints, shall be made to existing pipelines using appropriate adapters and slip collars.
- e) New cast *in-situ* manholes over existing wastewater sewers will only be permitted on lines of greater than 150mm diameter. The new entry point shall be at 45 degrees to

the direction of flow and the maximum invert at the entry point shall be the vertical tangent point of the live line (contained in Drawing 810).

## **8.7 Testing**

### **8.7.1 Air or Water Pressure Test**

All pipelines to be vested in Council ownership shall pass one of the following air or water pressure tests.

- a) Air Test – maximum 50mm drop in manometer tube for 300mm of water over 5 minutes.
- b) Water Test – at least 1.5m head at the high end and not more than 6.0m at the low end. Twenty four (24) hour pre-soaking required, measured over 30 minutes with acceptance being no more than 2ml/hr/mm of diameter/metre of pipe length.

Manholes shall be water tested to the lower rim of the cast iron lid.

### **8.7.2 Pipe Gauging**

All pipelines to be vested in Council ownership may be required to be tested for roundness using an appropriate gauging tool.

### **8.7.3 Closed-Circuit Television (CCTV) Inspection**

- a) All pipelines to be vested in Council ownership shall pass a closed circuit television (CCTV) inspection, carried out at an appropriate time agreed by Council or at the completion of the works.
- b) A professional operator with proof of experience in operating such devices shall carry out the CCTV inspection using a pan and tilt camera, in accordance with the technical specifications of the NZ Pipe Inspection Manual (published by the New Zealand Water & Wastes Association).
- c) The operator shall pan around every joint and check every lateral connection and defect.
- d) The video footage in DVD format, and the accompanying CCTV log sheets for each wastewater sewer length (as per the template in the NZ Pipe Inspection Manual), showing the features and condition of all inspected manhole lengths, shall be provided to Council. Video footage supplied without log sheets will not be accepted.
- e) Electronic log data to be supplied as csv, xls or mdb format, or other formats as approved. Tasman District Council's GIS or Confirm ID to be used as identifier.
- f) All pipelines shall be free of debris and flushed within 24-hours prior to inspection. Inspections of non-cleaned pipelines are not acceptable.
- g) A pipeline will fail its inspection if:
  - i. The pipe is horizontally misaligned or deformed by more than 5% of the pipe diameter.
  - ii. The pipe has visible dips or ponding of water.

- iii. The pipe has visible defects, such as open or displaced joints, defective or protruding laterals, cracked barrels or similar defects.
  - iv. There is evidence of infiltration at joints or laterals.
- h) Other testing as considered appropriate may be required by Council to ensure Council's future infrastructure will meet its projected life cycle.

**Appendix 8-1: Wastewater Connection Application**

To the **Engineering Manager**

Service Request No

I wish to apply for a connection to a live Council sewer main

The proposed connection must be either installed or supervised by Council's own contractor.

**DETAILS OF PROPERTY TO BE CONNECTED:** (refer to rate assessment)

Valuation Reference \_\_\_\_\_

Name of Owner \_\_\_\_\_

Property Address for connection \_\_\_\_\_

Road name and address \_\_\_\_\_

Multi Lot Subdivision connection      or      Single Lot connection (*choose one*)

**PLEASE PROVIDE DETAILS AND ANY COMMENTS – Attach sketch / plan:**

\_\_\_\_\_  
\_\_\_\_\_  
\_\_\_\_\_

**LIABILITY FOR CONNECTION COST AND/OR FEE (to be completed by person liable)**

I \_\_\_\_\_ agree to pay the connection cost and/or fee when invoiced by Council and annual rates/charges thereafter or otherwise provide information that it was paid prior to the issue of a 224 Certificate.

Signature \_\_\_\_\_ Date \_\_\_\_\_

Address for Invoice \_\_\_\_\_

**NAME AND ADDRESS OF APPLICANT**

Applicant's Name \_\_\_\_\_

Address \_\_\_\_\_

Signature \_\_\_\_\_ Contact Phone No \_\_\_\_\_ Date \_\_\_\_\_



# Drawing 800 Definition of Public Sanitary Sewer

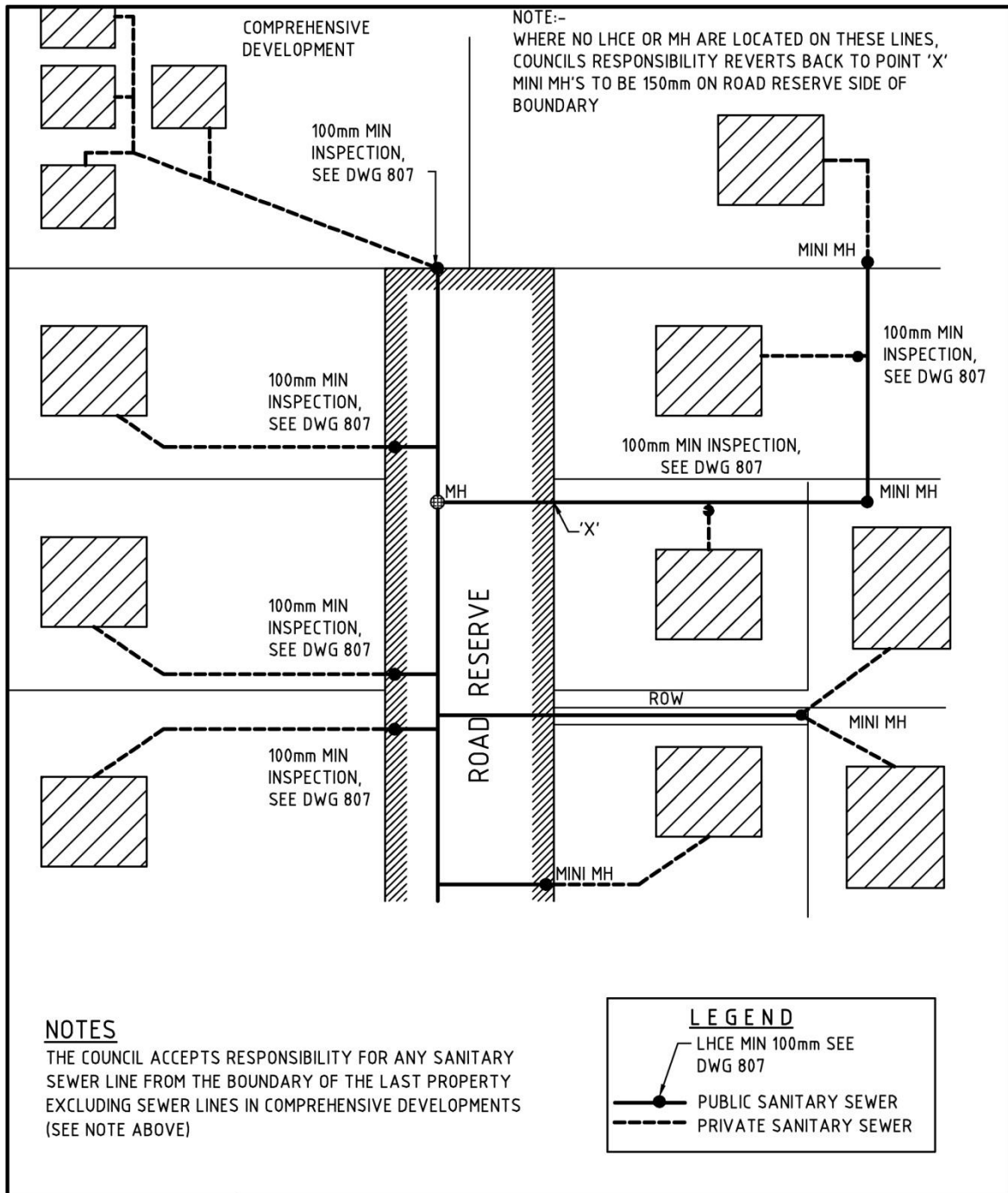

	<b>DEFINITION OF PUBLIC SANITARY SEWER</b>	
	<p style="text-align: center; margin: 0;"><b>ASSET MANAGEMENT ENGINEERING</b></p> <p style="margin: 0;">APPROVED <i>[Signature]</i></p> <p style="text-align: center; margin: 0;">ENGINEERING MANAGER</p>	<p style="margin: 0;">DRAWING No.</p> <p style="text-align: center; font-size: 24px; font-weight: bold; margin: 0;">800</p> <p style="margin: 0;">NOVEMBER 2013</p> <p style="text-align: center; margin: 0;">DATE</p>

**Drawing 801 Silt & oil trap**

**NOTES:**

1. THE STANDARD SILT & OIL TRAP IS DESIGNED TO SERVE SMALL INSTALLATIONS SUCH AS TRUCK DEPOTS ETC. (MAJOR INSTALLATIONS WILL REQUIRE SPECIFIC DESIGN.)
2. SILT & OIL TRAP IS MADE UP OF FOUR STANDARD PRECAST SUMP UNITS.
3. LIDS TO BE PRECAST REINFORCED CONCRETE LID MASS APPROXIMATELY 226kg.
4. OIL CAPACITY 390 LITRES. SILT VOLUME 0.1m<sup>3</sup>
5. DRAIN PIPE WORK MIN 100MM DIA PVC.
6. VENT PIPE WORK MIN 40mm DIA PVC, ABOVE GROUND VENTS MAY BE GALVANISED STEEL IF IN AN EXPOSED POSITION.
7. A CONTINUOUS MORTAR PAD MINIMUM THICKNESS 10mm, SHALL BE LAID ROUND THE TOP OF EACH SUMP UNIT TO ALLOW FOR SHAPING TO THE REQUIRED FINISHED GROUND LEVEL.  
A COMPRESSIBLE SEALANT STRIP OF COMPRIBAND OR SIMILAR APPROVED SHALL BE LAID ON EACH MORTAR PAD.
8. WHERE A STEAM CLEANING OPERATION OR DETERGENTS OR DEGREASER ARE USED:
  - \* AN APPLICATION FORM TO DISCHARGE TRADE WASTE FROM A SILT & OIL TRAP TO THE SEWERAGE SYSTEM SHALL BE SUBMITTED TO THE ENGINEERING MANAGER FOR HIS/HER APPROVAL.
  - \* STORMWATER SHALL NOT BE ALLOWED TO DISCHARGE TO THE SEWERAGE SYSTEM.
9. BUNDED AREAS AROUND FUEL STORAGE AREAS SHOULD DISCHARGE TO THE STORMWATER VIA A SUITABLY DESIGNED OIL INTERCEPTOR WITH AN APPROPRIATE SHUT-OFF VALVE INSITU.
10. BUND TO BE 200mm HIGH AROUND SITE.

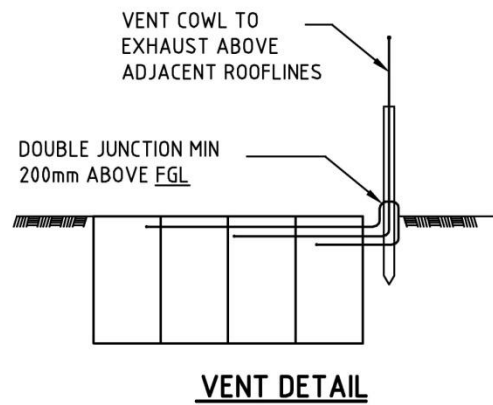
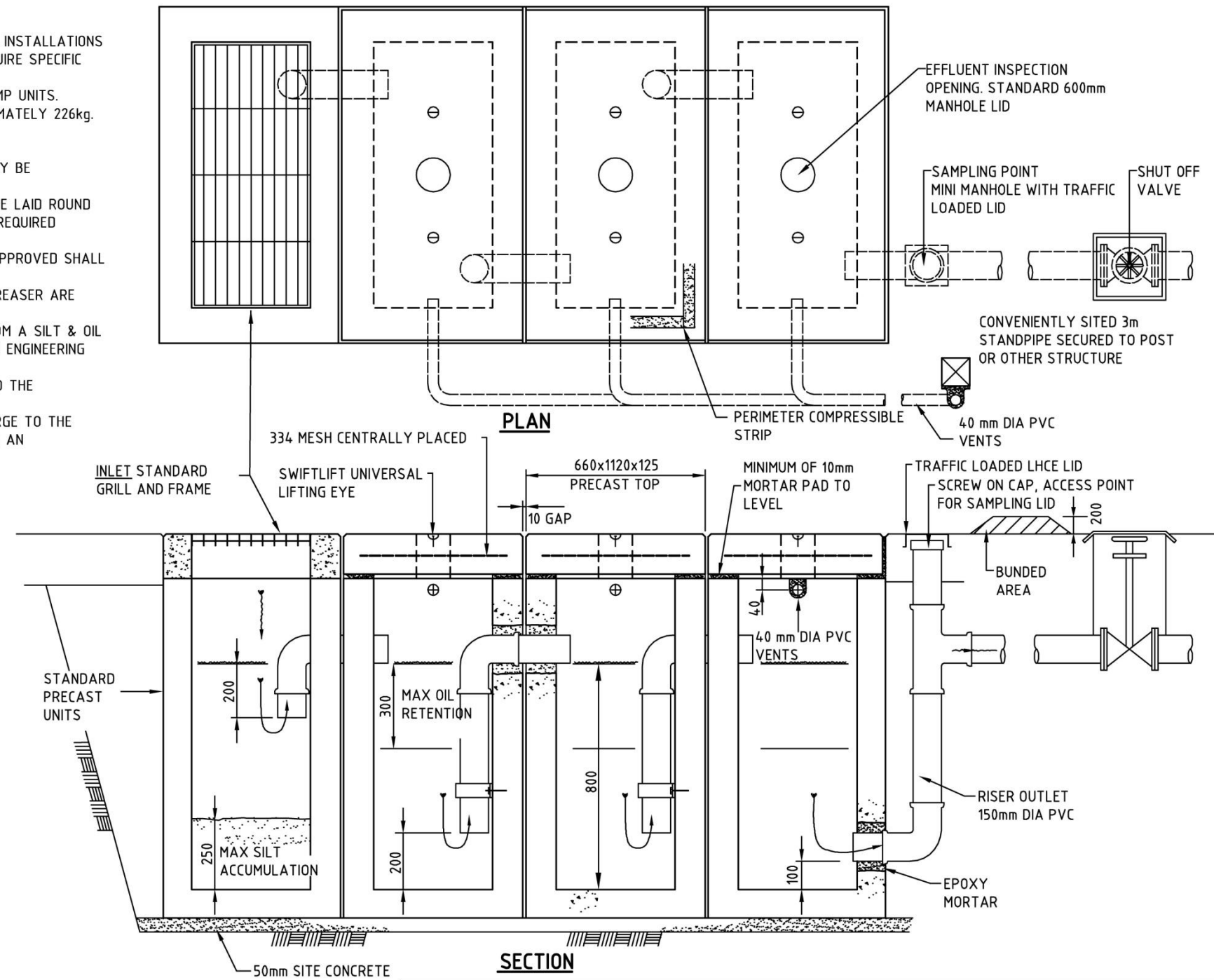

	<b>SILT &amp; OIL TRAP</b>	
	ASSET MANAGEMENT ENGINEERING APPROVED  ENGINEERING MANAGER	NOVEMBER 2013 DATE
		DRAWING No. <span style="font-size: 24px; font-weight: bold;">801</span>

Drawing 802 Standard sewerage manhole details

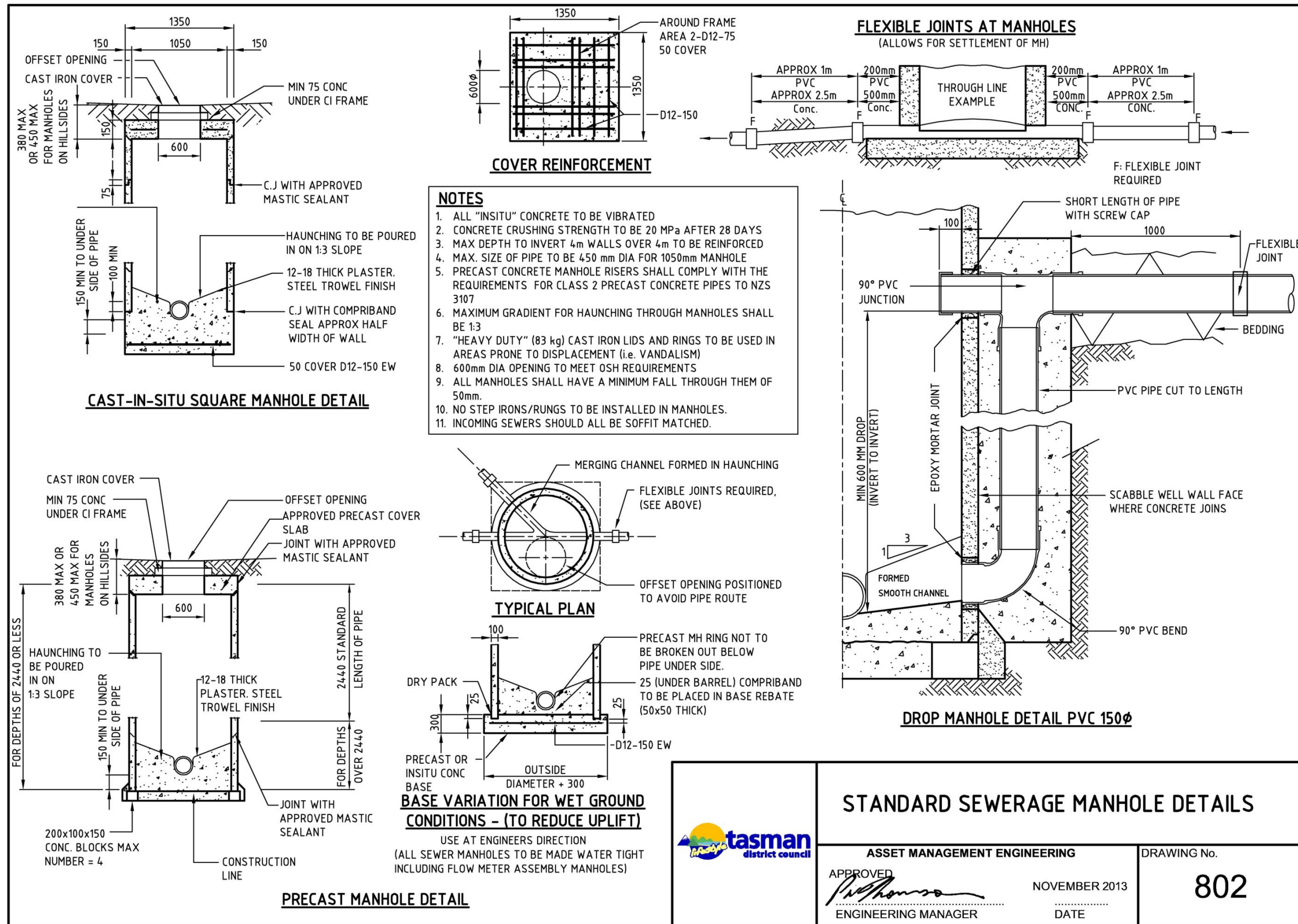

STANDARD SEWERAGE MANHOLE DETAILS

ASSET MANAGEMENT ENGINEERING

APPROVED *[Signature]* NOVEMBER 2013

ENGINEERING MANAGER DATE

DRAWING No. 802

**Drawing 803 Shallow mini-manholes**

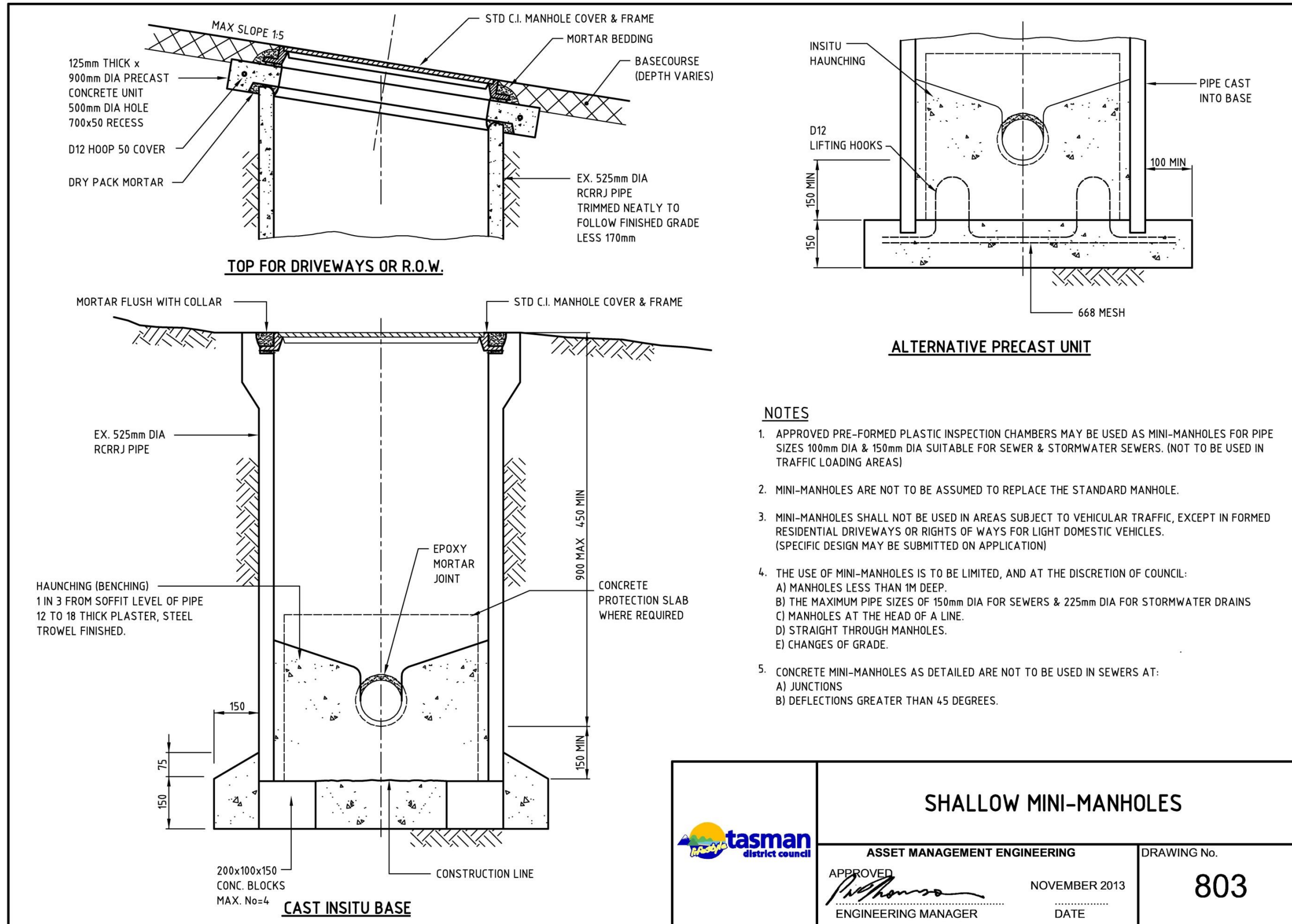

**NOTES**

1. APPROVED PRE-FORMED PLASTIC INSPECTION CHAMBERS MAY BE USED AS MINI-MANHOLES FOR PIPE SIZES 100mm DIA & 150mm DIA SUITABLE FOR SEWER & STORMWATER SEWERS. (NOT TO BE USED IN TRAFFIC LOADING AREAS)
2. MINI-MANHOLES ARE NOT TO BE ASSUMED TO REPLACE THE STANDARD MANHOLE.
3. MINI-MANHOLES SHALL NOT BE USED IN AREAS SUBJECT TO VEHICULAR TRAFFIC, EXCEPT IN FORMED RESIDENTIAL DRIVEWAYS OR RIGHTS OF WAYS FOR LIGHT DOMESTIC VEHICLES. (SPECIFIC DESIGN MAY BE SUBMITTED ON APPLICATION)
4. THE USE OF MINI-MANHOLES IS TO BE LIMITED, AND AT THE DISCRETION OF COUNCIL:
  - A) MANHOLES LESS THAN 1M DEEP.
  - B) THE MAXIMUM PIPE SIZES OF 150mm DIA FOR SEWERS & 225mm DIA FOR STORMWATER DRAINS
  - C) MANHOLES AT THE HEAD OF A LINE.
  - D) STRAIGHT THROUGH MANHOLES.
  - E) CHANGES OF GRADE.
5. CONCRETE MINI-MANHOLES AS DETAILED ARE NOT TO BE USED IN SEWERS AT:
  - A) JUNCTIONS
  - B) DEFLECTIONS GREATER THAN 45 DEGREES.

	<b>SHALLOW MINI-MANHOLES</b>	
	ASSET MANAGEMENT ENGINEERING APPROVED  ENGINEERING MANAGER	NOVEMBER 2013 DATE
		DRAWING No. <b>803</b>

# Drawing 804 Internal sewer drop manhole for existing manholes only

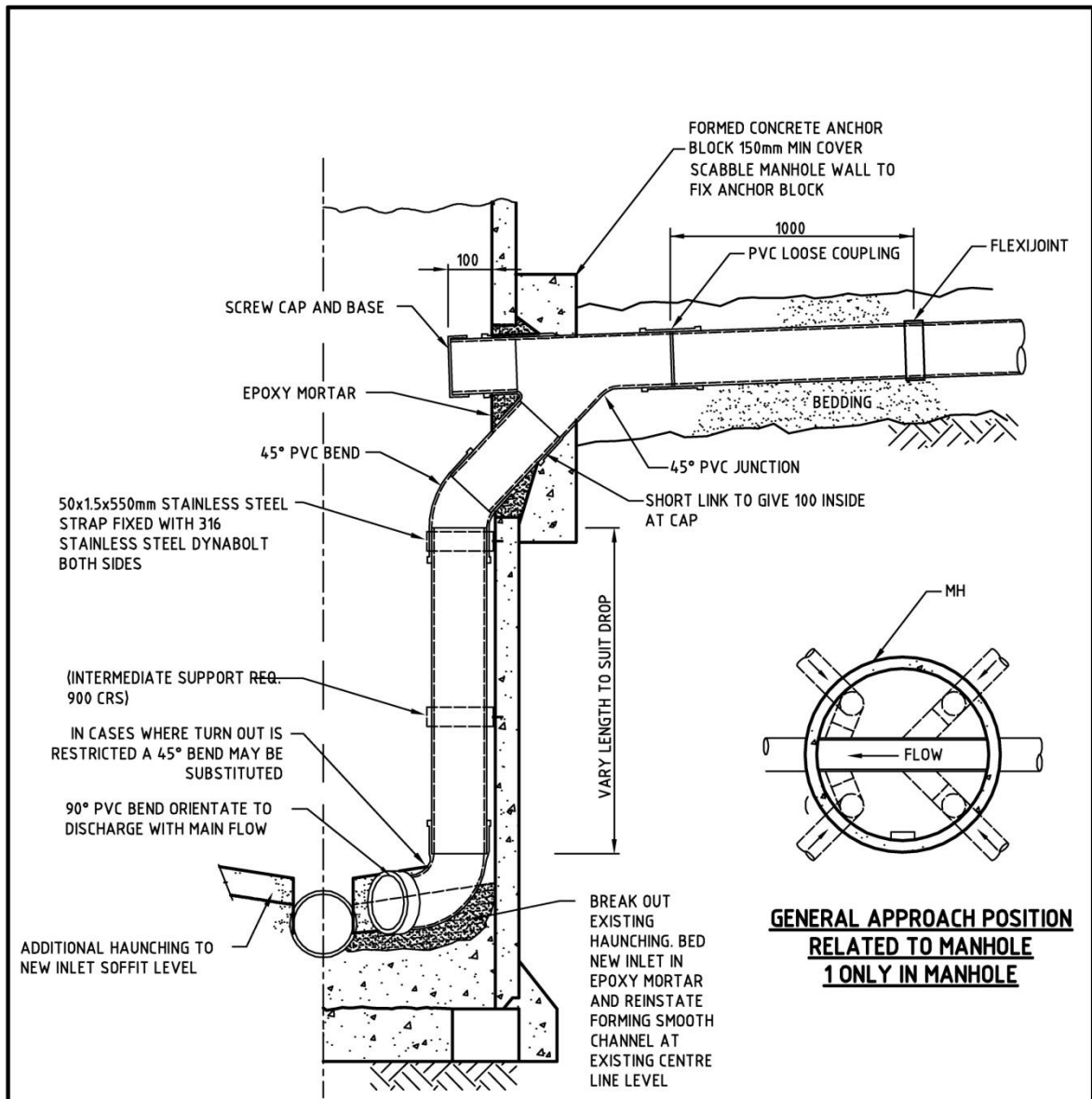

## INTERNAL DROP MANHOLE DETAIL PVC 150 Ø

TO BE USED IN SPECIAL CASES AT ENGINEERS DIRECTION FOR EXISTING MANHOLES ONLY

	<h3>INTERNAL SEWER DROP MANHOLE FOR EXISTING MANHOLES ONLY</h3>	
	<p>ASSET MANAGEMENT ENGINEERING</p> <p>APPROVED <i>P. Thompson</i> ENGINEERING MANAGER</p>	<p>NOVEMBER 2013 DATE</p>

# Drawing 805 Sewer drop manhole details

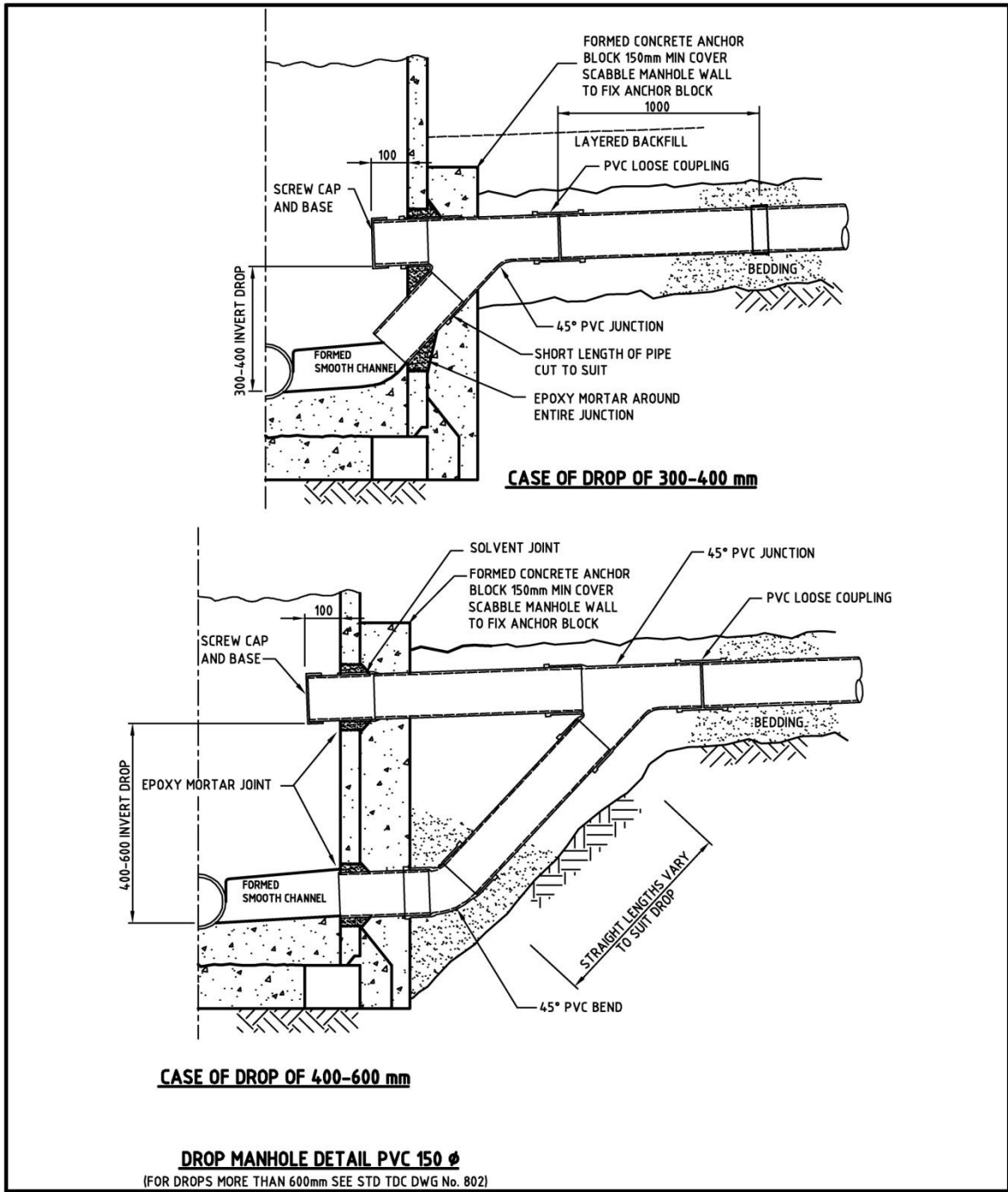

## SEWER DROP MANHOLE DETAILS



ASSET MANAGEMENT ENGINEERING

DRAWING No.

APPROVED  
*P. Thomson*  
 ENGINEERING MANAGER

NOVEMBER 2013  
 DATE

**805**

**Drawing 806 Miscellaneous manhole details (access frame clips)**

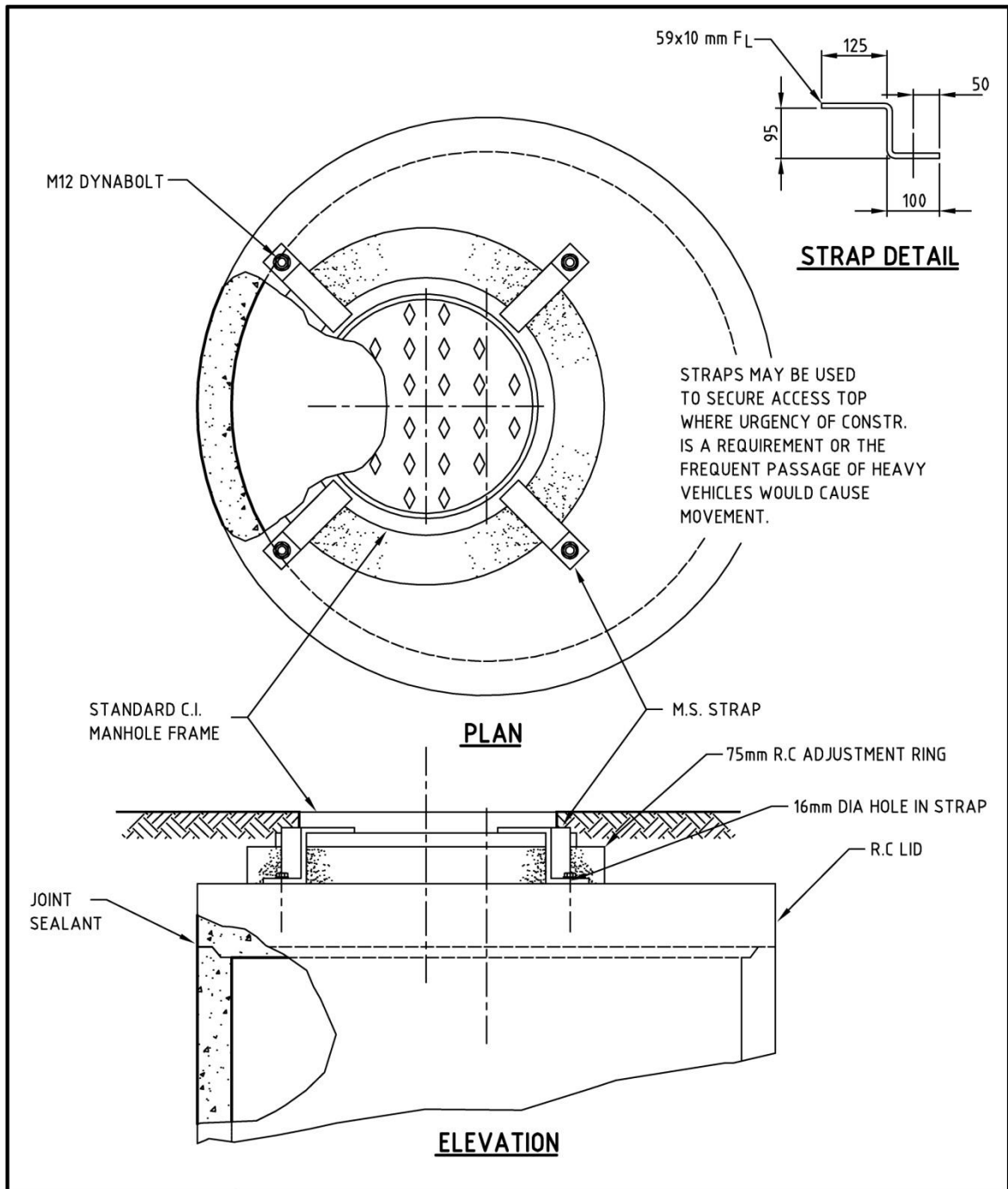

**MISCELLANEOUS MANHOLE DETAILS  
(ACCESS FRAME CLIPS)**



ASSET MANAGEMENT ENGINEERING

DRAWING No.

APPROVED  
*P. Johnson*  
ENGINEERING MANAGER

NOVEMBER 2013  
DATE

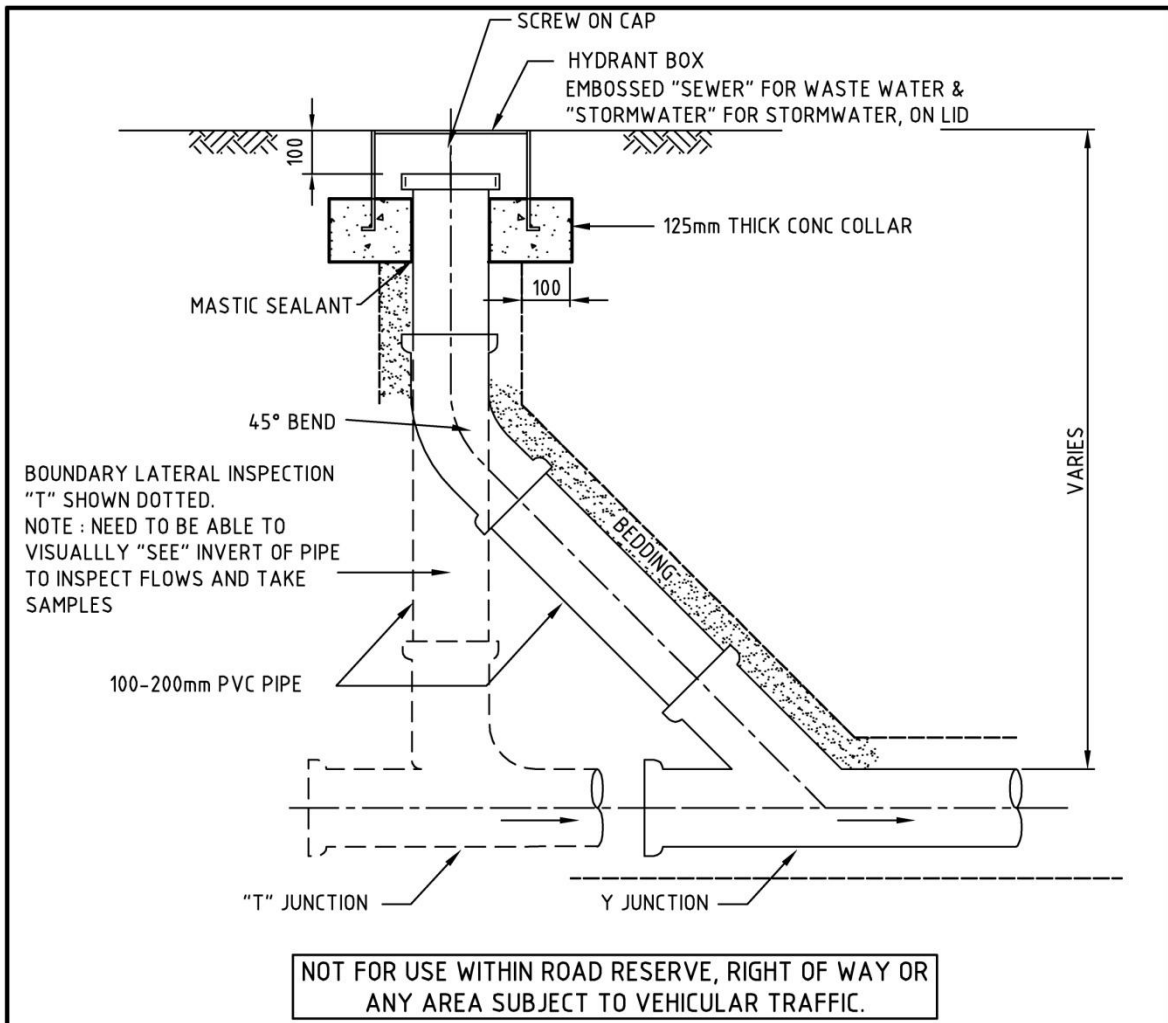

**806**

# Drawing 807 Lamphole cleaning eye (LHCE) (Non traffic loaded)



## NOTES

1. LAMP HOLE CLEANING EYES (LHCE), MAY BE USED IN LIEU OF MANHOLES IN ANY OR ALL OF THE FOLLOWING CIRCUMSTANCES
  - A) GENERALLY LHCE ARE FOR USE ON PRIVATE PROPERTY ONLY
  - B) ONLY ONE LHCE SHALL BE PERMITTED BETWEEN MANHOLES
  - C) LHCE MAY BE USED AT THE HEAD OF A DRAINAGE RUN
  - D) LHCE MAY BE USED WHERE ACCESS POINTS ARE REQUIRED AT INTERVALS OF LESS THAN 50 METERS
  - E) LHCE MAY BE USED AT THE TOP OF STEEP BANKS WHERE THE USE OF A STANDARD MANHOLE WOULD BE IMPRACTICAL
2. LHCE WILL NOT BE APPROVED FOR USE, WITHIN ROAD CARRIAGEWAYS, FOOTPATHS OR BERMS ONLY FOR USE AT TOP OF ROAD BATTERS/BANKS.

	<h2 style="margin: 0;">LAMP HOLE CLEANING EYE (LHCE) (NON TRAFFIC LOADED)</h2>	
	ASSET MANAGEMENT ENGINEERING APPROVED  ENGINEERING MANAGER	DRAWING No. <span style="font-size: 2em; font-weight: bold;">807</span> NOVEMBER 2013 DATE



## Drawing 808 Lamphole cleaning eye (LHCE) (right of way traffic loaded)

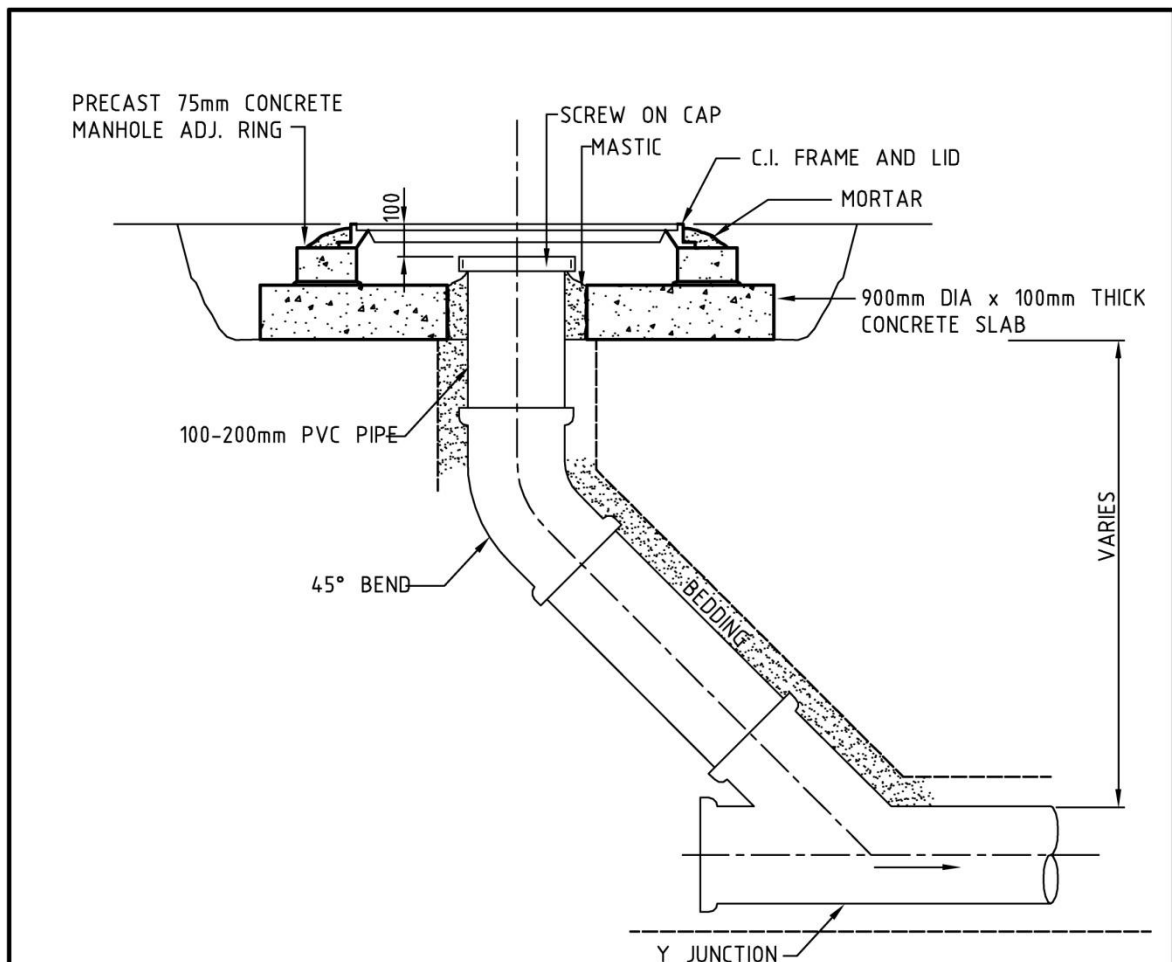

### NOTES

1. LAMP HOLE CLEANING EYES (LHCE), MAY BE USED IN LIEU OF MANHOLES IN ANY OR ALL OF THE FOLLOWING CIRCUMSTANCES
  - A) GENERALLY LHCE ARE FOR USE ON PRIVATE PROPERTY ONLY
  - B) ONLY ONE LHCE SHALL BE PERMITTED BETWEEN MANHOLES
  - C) LHCE MAY BE USED AT THE HEAD OF A DRAINAGE RUN
  - D) LHCE MAY BE USED WHERE ACCESS POINTS ARE REQUIRED AT INTERVALS OF LESS THAN 50 METERS
  - E) LHCE MAY BE USED AT THE TOP OF STEEP BANKS WHERE THE USE OF A STANDARD MANHOLE WOULD BE IMPRACTICAL
2. LHCE WILL NOT BE APPROVED FOR USE, WITHIN ROAD CARRIAGEWAYS, FOOTPATHS OR BERMS



## LAMP HOLE CLEANING EYE (LHCE) (RIGHT OF WAY TRAFFIC LOADED)

ASSET MANAGEMENT ENGINEERING

APPROVED

*P. Thomson*

ENGINEERING MANAGER

NOVEMBER 2013

DATE

DRAWING No.

808

# Drawing 809 Lamphole Cleaning Eye (LHCE) Location (non traffic loaded)

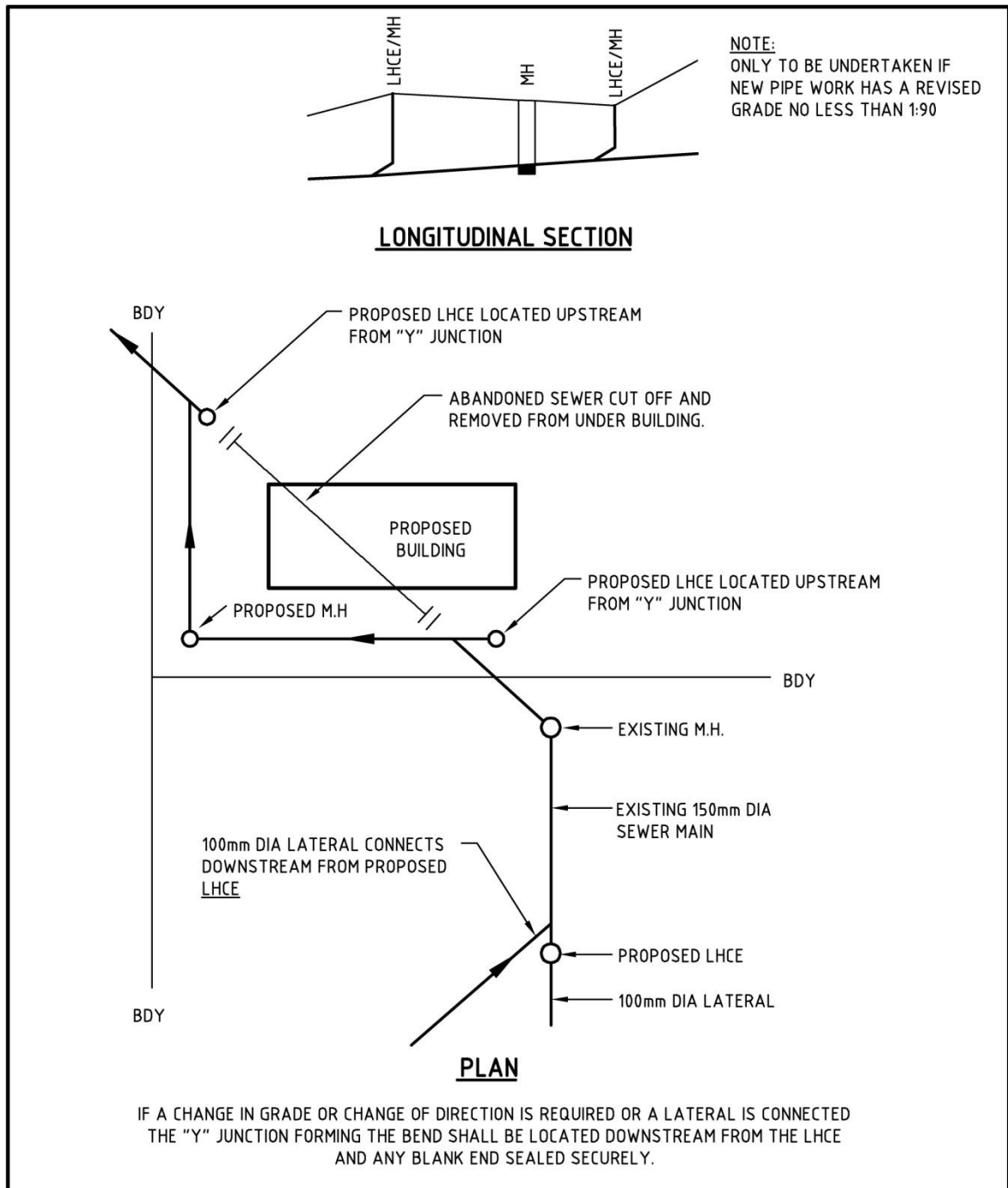

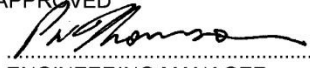
	<h2>LAMPHOLE CLEANING EYE (LHCE) LOCATION (NON TRAFFIC LOADED)</h2>	
	<p>ASSET MANAGEMENT ENGINEERING</p> <p>APPROVED</p>  <p>ENGINEERING MANAGER</p>	<p>NOVEMBER 2013</p> <p>DATE</p>
		<p>DRAWING No.</p> <h1>809</h1>

Drawing 810 Standard PVC pipe details

