



Chapter 7

Water

TABLE OF CONTENTS

CHAPTER 7	WATER	1
INTRODUCTION		1
7	PURPOSE	1
7.1	Performance Outcomes	1
7.2	Referenced Documents	2
7.2.1	District Plan Requirements	2
7.2.2	Building Code Requirements	2
7.2.3	External Standards	2
STANDARDS		4
7.3	Reticulation Design	4
	Mandatory Matters	4
7.3.1	General	4
7.3.2	Capacity and Layout	4
7.3.3	Structural Integrity	5
7.3.4	Level of Service	5
7.3.5	Design	5
7.3.6	Permitted Head Losses	6
7.3.7	Reservoir Head	6
7.3.8	Normal Working Demand Flows	6
7.3.9	Fire Fighting Demand Flows	6
7.3.10	Alterations to Existing Infrastructure	7
7.3.11	Depth of Water Mains	7
7.3.12	Level of Service	8
7.3.13	Water Pressure and Storage Requirements	8
7.4	Pipe Specifications	8
	Mandatory Matters	8
7.4.1	Pipe Size	8
7.4.2	Pipe Materials	9
7.4.3	Pipe Joints	10
7.4.4	Unrestrained Mechanical Couplings	10
7.4.5	PVC Pipe Joints	10
7.4.6	PE Pipe Joints	11
7.4.7	Welded Steel Pipe Joints	11
7.4.8	Seismic Design for Pipes	12
7.4.9	Watermains in Hydrocarbon Contaminated Ground	12
7.5	Fittings	12
	Mandatory Matters	12
7.5.1	Pipe Fittings	13
7.5.2	Corrosion Protection	13
7.5.3	Hydrants	14
7.5.4	Positioning of Valves	15
7.5.5	Depth of Valves	15
7.5.6	Sluice Valves	15
7.5.7	Rider Main Valves	15

7.5.8	Air Release Valves.....	15
7.5.9	Scour Valves.....	16
7.5.10	Butterfly Valves.....	16
7.5.11	Non-Testable Non-Return Valves.....	16
7.5.12	Valve Boxes.....	16
7.5.13	Restraint blocks.....	17
7.5.14	Thrust Block design.....	17
7.6	Water Supply Connections.....	19
	Mandatory Matters.....	19
7.6.1	Point of supply to customer.....	19
7.6.2	Service Connection Diameter.....	19
7.6.3	Individual Connections.....	19
7.6.4	Tapping Bands and Ferrules.....	19
7.6.5	Meter Assembly for 20mm and 25mm ID Connection.....	20
7.6.6	Meter Assembly for 32 - 40mm ID Connection.....	20
7.6.7	Meter assembly for 50mm ID and larger Connection.....	21
7.6.8	Water Meters.....	21
7.6.9	Backflow Preventers.....	22
7.6.10	Reuse of Existing Service Connections.....	22
7.6.11	Disconnections.....	22
7.6.12	Fire Sprinkler Supply.....	22
	Good Practice.....	23
7.6.13	General.....	23
7.7	Pumping and Storage.....	23
	Mandatory Matters.....	23
7.7.1	Pump Station Design.....	23
7.7.2	Access and Services.....	24
7.7.3	Electrical Equipment.....	24
7.7.4	Commissioning.....	25
7.7.5	Reservoir Requirements.....	25
7.7.6	Security of Water Supply Facilities.....	25
7.7.7	Private Pumping Stations.....	25
7.8	Construction and Installation.....	25
	Mandatory Matters.....	25
7.8.1	Trench Width.....	26
7.8.2	Base of Excavation.....	26
7.8.3	Trench Support.....	26
7.8.4	Trench Foundation Stability.....	26
7.8.5	Dewatering.....	26
7.8.6	Metal Bedding.....	26
7.8.7	Pipe Embedment.....	27
7.8.8	Geotextiles.....	27
7.8.9	Concrete Protection.....	27
7.8.10	Water Stops and Trench Groundwater.....	27
7.8.11	Pipe Installation.....	28
7.9	Trenchless Technology.....	28
	Mandatory Matters.....	28
7.9.1	General.....	28
7.9.2	Tracer Tape.....	29
7.9.3	Tracer Tape Installation.....	29
7.9.4	Tracer Wire.....	29

7.9.5	Tape or Wire Testing	29
7.9.6	Testing, Disinfection and Connection	30
	Good Practice.....	30
7.9.7	Trenching	30

LIST OF TABLES

Table 7-1	Standards and Publications Related to the Design and Construction of Water Supply Services ..	2
Table 7-2	Water Supply Levels of Service	5
Table 7-3	Design Demand Flows	6
Table 7-4	SNZ PAS 4509 Fire Fighting Flow, Pressure and Storage Requirements	8
Table 7-5	General Pipe Specifications	9
Table 7-6	Pipe Thrust Block Design.....	18
Table 7-7	Approved Water Meters and Meter Boxes	21
Table 7-8	Water Stops Spacing and Gradient	28

APPENDICES

Appendix A	Water Meter Location Form
Appendix B	Rural Water Supply – Tasman District Council Only

CHAPTER 7 WATER

INTRODUCTION

7 PURPOSE

The Council seeks to create and manage a water supply network that will distribute water for consumption and fire-fighting purposes, and which meets the appropriate standards and level of service for these uses, delivered in an efficient, safe and sustainable way.

7.1 Performance Outcomes

Water supply performance outcomes for network assets sought by these standards are set out as follows. They are subject to the objectives, policies and rules of the Nelson and Tasman RMPs:

- a) Drinking water quality that ensures the health and safety of people and communities;
- b) A water supply network that has adequate capacity, pressure, and points of connection to provide water for all community needs including fire-fighting purposes;
- c) A water supply network that minimises risk of contamination;
- d) A water supply network that has sufficient capacity to accommodate reasonably foreseeable future demand;
- e) A network that is located in such a way as to adequately service each lot;
- f) A network that is accessible for maintenance;
- g) New supply infrastructure that will minimise adverse effects on, and be compatible with, the existing water reticulation network, including existing equipment used by Council;
- h) A water supply network that will minimise disruption to other parts of the network during maintenance by having adequate interconnections, valves, and separating trunk main supplies from local reticulation;
- i) Is located, constructed and uses materials in a manner that minimises the potential for damage or disruption due to natural hazards;
- j) A network that is robust and durable, able to withstand, external pressures such as tree roots and ingress of contaminants, as well as internal pressures such as water chemistry and pressure surges; and
- k) A network that is affordable over the whole-of-life of the system, including maintenance, operations and replacement or renewal costs.
- l) Water is sourced in a manner that protects the mauri of water and opportunities for Mahinga kai.

All performance outcomes are also subject to the applicable RMP objectives and policies and appropriate water supply bylaws which take precedence over the requirements of the Nelson Tasman Land Development Manual (NTLDM).

7.2 Referenced Documents

7.2.1 District Plan Requirements

The standards set out in this chapter address matters that are specific to Council asset creation or activities that may have an impact on an asset. They are subject to the respective Nelson City and Tasman District RMPs. Regarding water supply, key sections are subdivision and land use building construction and alteration.

7.2.2 Building Code Requirements

Private property connection to a Council provided water supply is also addressed under the Building Act and NZ Building Code (NZBC).

A Building consent is required for that connection and is to be supported with the appropriate plans and specifications (Section 45 of the Building Act 2004) that demonstrate compliance with the performance requirements of NZBC clause G12 (“Water supplies”). The information required includes, but is not limited to, the setting out of the water pipe, from the boundary of the property to the building(s) concerned, plus measures to protect the pipework.

7.2.3 External Standards

Unless otherwise specified within the standards of this document, water supply networks will be designed and constructed in a manner consistent with the standards set out in Table 7-1. Where an Act or National Standards document is referenced, this will be the current version including any associated amendments.

Table 7-1 Standards and Publications Related to the Design and Construction of Water Supply Services

Standard	Comment
	Council traffic management guidelines
SNZ PAS 4509	New Zealand Fire Service Fire Fighting Water Supplies Code of Practice
NZS 4404:2010	Land development and subdivision engineering
NZS/BS 21	Pipe threads for tubes and fittings
NZS 4522	Underground fire hydrants and surface box frames and fittings
AS/NZS 4793	Mechanical tapping bands for waterworks purposes
AS1646	Elastomeric seals for water works purposes
AS/NZS 1477	PVC Pipes and fittings for pressure applications
AS/NZS 2032	Installation of PVC pipe systems
AS/NZS 2033	Installation of polyethylene pipe systems
AS 2129	Flanges for pipes
AS/NZS 2280	Ductile iron pipes and fittings
AS/NZS 2544	Grey iron pressure fittings
AS/NZS 2566	Part 1 Buried flexible pipelines – Structural design Part 1 Supplement 1: Buried flexible pipelines – Structural design – Commentary Part 2 Buried flexible pipelines - Installation

Standard	Comment
AS/NZS 2638	Gate valves for water works purpose – resilient-seated
NZS 4058	Specification for pre-cast concrete drainage and pressure and non-pressure pipes
NZS 3109	Concrete construction
NZS 3121	Specification for water and aggregate for concrete
BS 3412	Methods of specifying general purpose PE materials for moulding and extrusion
NZS 3501	Specification for copper tubes for water, gas and sanitation
AS 3572	Glass filament reinforced plastics
NZS 3604	Timber framed buildings
AS/NZ S3725	Loads on buried concrete pipes
AS/NZS 4020	Testing of products for use in contact with water
AS/NZS 4087	Metallic flanges for water works purposes
AS/NZS 4129	Fittings for PE pipes for pressure applications
AS/NZS 4130	Polyethylene (PE) pipes for pressure applications
AS/NZS 4158	Thermal bonded polymeric coatings on valves and fittings for water industry purposes
AS 4181	Stainless steel clamps for water purposes
AS/NZS 4331	Metallic flanges – Part 2: Cast iron flanges
AS/NZS 4441	Oriented PVC (PVC-O) pipes for pressure applications
NZS 4442	Welded steel pipes and fittings for water, sewage, and medium pressure gas
NZS 4501	Code of practice for the location and marking of fire hydrants
AS/NZ S4765	Modified PVC (PVC – M) pipes for pressure applications
AS/NZS 4998	Bolted unrestrained mechanical couplings for waterworks purposes
NZS/BS 5163	Specification for predominantly key operated cast iron gate valves for water works purposes
AS 3571/AS 3572	Glass reinforced plastics (GRP) pipes joints and fittings
www.astt.com.au	Australasian Society of Trenchless Technology
Ministry of Business, Innovation and Employment	NZ Building Code - G12 and B2
DWSNZ	Drinking-water Standards for New Zealand
Bylaws	Nelson City Council and Tasman District Council Water Supply Bylaws

STANDARDS

7.3 Reticulation Design

This section sets out Council's expectation for the design of the layout, capacity, connection points, flow and pressure of the water supply reticulation.

Mandatory Matters

Council requires the following standards to be met in the design of the water supply reticulation:

7.3.1 General

7.3.1.1 A water supply network will deliver quality water to the point of supply that complies with the Drinking-water Standards for New Zealand 2005 (Revised 2008).

7.3.1.2 The water network will minimise the risks of contamination being introduced into the water.

7.3.2 Capacity and Layout

7.3.2.1 The water supply network will have sufficient capacity to provide adequate flow and pressure to meet the anticipated demand over its lifetime. Allowing for ultimate future development potential¹ within the catchment or adjoining catchments.

7.3.2.2 The water supply network will meet the fire protection requirements of the NZ Fire Service Fire Fighting Water Supplies Code of Practice 4509.

7.3.2.3 The water supply network will be located in such a way as to adequately service each lot and provide reasonable access for maintenance. It will not be located on private land.

7.3.2.4 The design of the water supply network will:

- a) Minimise adverse effects on, and be compatible with, the existing water reticulation network;
- b) Minimise disruption to other parts of the network during maintenance by having adequate interconnections, valves, and separating trunk main supplies from local reticulation;
- c) Utilise mechanical, electrical, alarm and telemetry equipment which is compatible with existing equipment used by Council;
- d) Make provision for access and maintenance of any component where the expected life of that component is less than that of the system of which it is a part;
- e) Ensure that mechanical and electrical equipment is either designed for submergence or located above the 100-year design flood level;
- f) Minimise whole of life costs;
- g) No water reticulation is to be constructed within private property or Council reserves;
- h) Water reticulation must be located a minimum of 1.5 metres from any boundary line.

¹ Development potential means the likely future development within the Services Overlay taking into account the Council's Strategic Development Plan and the LTP, and the provision of services in a manner that integrates with and does not foreclose this likely future development.

7.3.3 Structural Integrity

- 7.3.3.1 The water supply network will be constructed of materials compatible with the chemical properties of the water being conveyed, be suitable for the intended duty, have a minimum design life of 70 years and have a proven performance record.
- 7.3.3.2 The water supply facility will minimise leakage, eliminate the ingress of contaminants, and the penetration of roots, using current best practice.
- 7.3.3.3 The water supply facility will provide electrical and mechanical equipment with a life span and quality of the best currently available technology.
- 7.3.3.4 The facility will withstand all anticipated superimposed loads and network pressures (including those from transient surges that could reasonably be expected from pump failure, pump starts, and sudden valve closure).

7.3.4 Level of Service

- 7.3.4.1 Table 7-2 sets out the minimum levels of service required for urban water supply reticulation. Any proposed water supply system (or extension to an existing water supply system) will be adequate to meet these levels of service at the time of design and the reasonably foreseeable future.

Table 7-2 Water Supply Levels of Service

Design Criteria	Level of Service Required
SNZ PAS 4509: 2008 - NZ Fire Service Fire Fighting Water Supplies Code of Practice	Full compliance with FW2 and every part of the network
Connection	Each lot will have an individual metered connection and appropriate backflow for the site
Minimum flow at each connection	30 litres per minute for design flows (also refer to Table 7-3)
Minimum normal working residual pressure	300 kPa at the point of supply
Maximum static water pressure	900 kPa at the point of supply

Note: Any lots and buildings provided with private, on-site systems will meet the requirements of the appropriate Resource Management Plan (RMP).

7.3.5 Design

- 7.3.5.1 All proposed reticulated water supplies must comply with the minimum levels of service shown in Table 7-2 for both normal demand flows and fire-fighting flows.
- 7.3.5.2 For residential development, network design and pipe sizes will be determined by fire-fighting flows. As a minimum, the Designer must demonstrate compliance with fire-fighting code of practice.
- 7.3.5.3 Principal mains will be not less than 150mm ID (see also, Table 7-5) and will be laid on one side of all public roads in every residential development.
- 7.3.5.4 Rider mains will be not less than 50mm ID in residential development (see also Table 7-5) and will be laid along the road frontage of all lots not fronted by a principal main and looped back to the principal main to avoid dead ends. The principal mains serving commercial and industrial

developments will be at least 150mm ID on one side of the road with a 100mm ID main on the other side.

7.3.5.5 The Council will have the right to specify the diameters to be used for the principal water mains within the development with regard to the Council's Strategic and Management Plans.

7.3.5.6 Regarding working pressure or pressures at the point or points of connection to the existing reticulation, when such data is not available or at the Council's request, it will be the responsibility of the designing engineer to obtain the information through independent flow and pressure tests.

7.3.6 Permitted Head Losses

7.3.6.1 The new water supply reticulation will be designed to mitigate large fluctuations in residual pressure as demands vary and minimise the losses of pressure along the watermains. Head losses in the watermains will not exceed approximately 20kPa/kilometre at peak domestic demand (i.e. 2 metres of head loss per 1000 metres of pipeline). Higher losses may be approved by the Council on a case-by-case basis.

7.3.7 Reservoir Head

7.3.7.1 For design purposes, the hydraulic head at a reservoir will be taken with the reservoir being 50% full.

7.3.7.2 Water connections will be located so that properties at the highest location receive a pressure of 300kPa at the point of supply measured from the bottom operational water level of the reservoir and properties at the lowest location receive a pressure not more than 900 kPa from the top operational water level of the reservoir at the point of supply without the use of a PRV valve.

7.3.8 Normal Working Demand Flows

7.3.8.1 When the source of supply is a pressure-reducing valve the hydraulic head will be the head the pressure-reducing valve is set to.

7.3.8.2 The minimum flow and normal working residual pressure level of service criteria specified in Table 7-3 will be satisfied for all reticulation when using the following demand flows.

Table 7-3 Design Demand Flows

Development Type	Design Flows
Residential	52 litres per person per peak hour 624 litres per person per day (peak day) 1560 litres per dwelling per day (assuming 2.5 persons per dwelling)
Commercial and Industrial	Specifically assessed by the Designer

7.3.9 Fire Fighting Demand Flows

7.3.9.1 All reticulation (and storage) design must fully comply with the requirements of the NZ Fire Service Fire Fighting Water Supplies Code of Practice (SNZ PAS 4509), hereafter called the Code of Practice.

7.3.9.2 For compliance in residential areas under classification FW2, a simultaneous flow of 12.5 l/s is required from two fire hydrants with maximum hydrant spacing of 135.0m. Each hydrant is to be no closer than 6.0m and no further than 135.0m from the potential fire source, refer Table 7-4.

7.3.10 Alterations to Existing Infrastructure

7.3.10.1 Regarding alterations to existing reticulation, any alteration (upgrading, relocation and lowering of watermains and other water supply element(s), required for compliance of the new development to the Council's standards will be at the Developer's cost. The connections to the existing reticulation will be undertaken by a contractor approved by the Council, at the Developer's cost.

7.3.10.2 No connection to Council's reticulation will be permitted until all new reticulation has been adequately flushed of all construction debris and sterilised.

7.3.11 Depth of Water Mains

7.3.11.1 The following standards apply to the installation of water mains:

- a) Water mains will be installed to comply with SD701 to SD709 and AS/NZS 2566.2;
- b) Both principal mains and rider mains will have the following cover, except in circumstances requiring special protection. Greater depth will be provided if required by Council;
- c) Under grass berms and footpaths in residential areas, the top of pipe for water mains is 600mm below the finished surface (minimum) and 900mm (maximum). In commercial and rural areas, the top of pipe for water mains is 750mm (minimum) and 1000mm (maximum) below the finished surface;
- d) Under carriageways, the top of pipe is 750mm (minimum) and 1000mm (maximum) below finished surface level, measured at the lowest point of the carriageway;
- e) The sections of watermain adjacent to a driveway/vehicle crossing will be gradually deepened, to allow the specified cover under the driveway/vehicle crossing without the provision of vertical bends. Similar provision will be made to give the specified cover over valve and hydrant spindles;
- f) In berms, service connection pipes will have a minimum cover of 350mm and maximum cover of 500mm. In the carriageway, right-of-way or accessway, service connection pipes will have a minimum cover of 450mm and maximum cover of 750mm. At the meter box or rider main valve, the pipe is permitted to have lesser cover where it is raised to suit the fitting height.

7.3.11.2 Council will not accept public water supply pipes located through private property within the urban area.

7.3.11.3 Rural pipelines crossing private property may be permitted if no other reasonable routes are available. All new pipework crossing private property must be protected with a three-metre-wide easement-in-gross in favour of Council.

7.3.11.4 Building over or alongside a Public Watermain

- a) Buildings over any water reticulation are not permitted;
- b) Buildings alongside (within 1.5m) of any water reticulation will require a specific foundation design to be submitted to the Engineering Manager for written approval.

7.3.12 Level of Service

- 7.3.12.1 Council may require water mains or water supply facilities to be installed to a higher specification (capacity or strength) to provide for future development.
- 7.3.12.2 The Council's reticulation and asset plans should be carefully referred to when designing extensions to, or amendments to the existing water supply reticulation.
- 7.3.12.3 Regarding supply requirements, Council, at its discretion may require demonstration of compliance for normal demand, or to a nominated higher standard.
- 7.3.12.4 For commercial or industrial development, network design should be determined by normal demand flows or fire-fighting flows and the Designer must demonstrate analysis of both scenarios.
- 7.3.12.5 The Council may provide details of the working pressure or pressures at the point or points of connection to the existing reticulation that may be used for design purposes.

7.3.13 Water Pressure and Storage Requirements

- 7.3.13.1 Table 7-4 summarises the more general requirements of the Code of Practice for Normal Reticulation Design. Further specific reference to the requirements Code of Practice may be required for unusual situations.

Table 7-4 SNZ PAS 4509 Fire Fighting Flow, Pressure and Storage Requirements

Fire water class	Reticulated Water Supply				Non-reticulated water supply	
	Hydrant flow required within a distance of 135m (l/s)	Additional Hydrant flow required within a distance of 270m (l/s)	Maximum number of fire hydrants to provide flow	Residual water pressure at hydrants	Time (fire-fighting) (min)	Volume (m ³)
FW1	7.5	-	1	100 kPa	15	7
FW2	12.5	12.5	2	100 kPa	30	45
FW3	25	25	3	100 kPa	60	180
FW4	50	50	4	100 kPa	90	540
FW5	75	75	6	100 kPa	120	1080

Note: See the Fire-Fighting Code of Practice for additional notes and other specific requirements.

7.4 Pipe Specifications

This section sets out Council's expectations for pipes, including general specifications, materials, sizes, joints and seismic and liquefaction standards.

Mandatory Matters

Council requires the following standards to be met in determining pipe design and materials choices:

7.4.1 Pipe Size

- 7.4.1.1 Table 7-5 sets out the general pipe size, material, and pressure specifications for principal and rider mains.

Table 7-5 General Pipe Specifications

	Principal Mains	Rider Mains
Pipe Size	Generally, not less than 150mm nominal ID Standard pipe sizes (see Section 7.3.5 - Design): DN 100 (with specific approval), DN 150, 200, 250, 300, 375, 450, 525 and 575mm nominal ID	Not less than DN 63 (50mm nominal ID)
Acceptable Materials and Specification	PVC-U or (Series 1 or Series 2 dimensions) PVC-M Series 1 or Series 2 or PVC-O (with specific approval) PE 80 (MDPE) (with specific approval) PE100 (with specific approval) Concrete lined steel (arc butt welded) Concrete Lined Ductile iron Hobas GRP (with specific approval)	PE 80 (MDPE), PN12.5 or PE100 PN16 PVC-U (DN 50mm internal diameter only Series 1 dimensions, not less than PN15) MDPE (must be used for valve upstands, see SD 707)
Pressure class	No less than PN12 A higher class will be required in higher pressure zones.	
Pipe colour	To suit purpose	

Notes:

- 1) PVC and PE pressure pipes in New Zealand and Australia are usually referred to by their nominal diameter or “DN”;
- 2) By Convention, PVC pipes, steel, and ductile iron pipes are referred to by their nominal INTERNAL diameter (i.e. DN50, 100, 150 etc) and either Series 1 (metric sizes) or Series 2 (Imperial or CIOD sizes);
- 3) PE pipes are usually referred to and specified by their nominal OUTSIDE diameter (i.e. DN 63, 125, 180mm OD etc);
- 4) DN 63 = 50mm nominal internal diameter, DN 125 = 100mm nominal internal diameter, DN 180 = 150mm nominal internal diameter;
- 5) In any instance where an external diameter is shown on a drawing or specified it will be annotated “OD”. Dimensions in absence of either “ID” or “OD” will be assumed by Council to refer to a nominal internal diameter (“ID”);
- 6) Minimum and standard pipe sizes for principal and rider mains are shown in Table 7-5;
- 7) PVC pipes should generally be specified in metric (Series 1) sizes, but imperial (series 2) sizes may be required in some instances for specific pipelines to achieve compatibility with Council’s existing pipe system. Series 1 (metric) sizes or Series 2 (imperial) sizes are listed in the relevant PVC pipe manufacturing standards.

7.4.2 Pipe Materials

7.4.2.1 PVC-U or pipes are acceptable in all normal circumstances for principal mains.

7.4.2.2 PVC-M or PVC-O pipes may be approved on application. Installation will be to AS/NZS 2032 and AS/NZS 2566 Part 2, with particular attention to the anchoring of valves and hydrants against displacement in operation. Refer SD 703 and 704 and NZS 4404, Appendix A “Acceptable Pipe Materials”.

- 7.4.2.3 PE or PVC pipes will be used in all rider mains.
- 7.4.2.4 All PE pipes will be produced from PE compound complying with AS/NZS 4130 and PIPA Technical Specifications POP 004 (polyethylene pipe and fittings compounds).
- 7.4.2.5 PE pipes will require specific approval by the Engineering Manager. For PE pipes PE80 PN12.5 material is the standard used. PE100 PN16 may be required in high pressure areas. For PE pipes DN 125 and larger, PE 100 is the Standard used.
- 7.4.2.6 Pipes of differing compositions will not be mixed within a common pipe length, (i.e. valve-to-valve). Installation of PE pipes will be to AS/NZS 2033 and AS/NZS 2566 Part 2.
- 7.4.2.7 Concrete lined steel pipes that are required in potentially unstable ground, for lengths of exposed pipe, or in other special cases, will be the subject of specific design. Suitable corrosion protection will be provided. Steel pipes laid underground will have an extruded blue or black HDPE external coating. Pipe laid above ground will have a black HDPE coating or will have an approved epoxy coating applied by a specialist applicator.
- 7.4.2.8 Ductile iron pipes will require specific approval of Council. Ductile iron pipes will be sleeved with a polyethylene sleeve, conforming to AS 3681.
- 7.4.2.9 PE100 may be used where higher pipe strength or higher-pressure class is required or increased capacity is an important criterion.

7.4.3 Pipe Joints

- 7.4.3.1 Where a rider main is to be extended at right angles to a principal main, an elongated gibault will be used (see SD705).
- 7.4.3.2 Where a rider main is to be extended along the same alignment beyond the end of the principal main, it will normally be connected in accordance with SD706.

7.4.4 Unrestrained Mechanical Couplings

- 7.4.4.1 Old style 'Gibault' joints have been superseded by new "universal" design bolted unrestrained mechanical couplings, conforming to AS/NZS 4998, for all pipes except PE where only end load restraint compression fittings, or heat fusion fittings, conforming to AS/NZS 4129, will be used.
- 7.4.4.2 Unrestrained Mechanical Couplings will be category 2 (50-year life) to AS/NZS 4998:2009.

7.4.5 PVC Pipe Joints

- 7.4.5.1 Joints for PVC pipes will be integral thermoformed socket/spigot rubber ring type (Z joints or locked-in-place Blueseal/Forsheda/Reiber style), with a biocidal lubricant. Elastomeric seal rings will conform to AS 1646.
- 7.4.5.2 Unrestrained Mechanical Couplings (repair couplings) will only be used to close a section of pipe where no other fittings are possible, or to adapt PVC pipe to existing in situ pipes, such as cast iron, asbestos cement, steel or ductile iron, or to connect PVC pipe to a purpose made ductile iron spigoted fitting.
- 7.4.5.3 Solvent cement joints on reticulation will not be permitted without the written approval of the Engineering Manager.

7.4.6 PE Pipe Joints

- 7.4.6.1 All PE pipe less than or equal to DN63 (50mm OD) will be joined by end load restraint mechanical seal ring compression joints to AS/NZS 4129, appropriate for the type of pipe (e.g. "Plasson, "Philmac") and rated to PN16 maximum working pressure.
- 7.4.6.2 All PE pipes DN125 (100 mm ID) or larger will be joined by butt-fusion joints or electrofusion fittings conforming to AS/NZS 4129.
- 7.4.6.3 Butt-fusion joints will comply with PIPA Technical Specification POP 003 (Butt Fusion Jointing of PE Pipes and Fittings – Recommended Parameters).
- 7.4.6.4 Electrofusion joints will comply with POP 001 (Electrofusion Jointing of PE Pipes and Fittings for Pressure Applications).
- 7.4.6.5 PE pipes will be installed in accordance with AS/NZS 2033 and AS/NZS 2566.
- 7.4.6.6 Certified tradespersons (as required in 7.4.6.8) approved by Council, will be employed with semiautomatic or fully automatic welding equipment specifically designed for the task.
- 7.4.6.7 All butt welding or electrofusion welding equipment must be data log capable and all log information must be made available to Council on request. The contractor will provide their own power source and earth leakage protection for the safety of their personnel. No manual welding of pipe joints will be accepted.
- 7.4.6.8 For electrofusion and butt welding, only personnel trained and holding a current certificate of competency in the system to be used, will be permitted by Council to carry out the work. A copy of the current certificate must be provided to Council before any welding proceeds.
- 7.4.6.9 The use of electrofusion joints on HDPE pipes is a specific task that requires special adherence to quality materials and certified equipment, a clean and dry site and electrofusion jointing qualified personnel. NZS 4130 generally outlines Polyethylene Pressure pipes criteria and the TEPPFA Technical Guidance document - AGU/2014/01 (A good practice guide for the electrofusion jointing of larger diameter polyethylene and pressure pipes).

7.4.7 Welded Steel Pipe Joints

- 7.4.7.1 Welded joints in steel pipes will be either butt joints or full penetration butt weld with an external welding band or bevelled. All welds will be fillet welds of 7mm or larger, applied in the field. All welding is to be undertaken by certified personnel approved by Council. A copy of the current certificate must be provided to Council before any welding proceeds.
- 7.4.7.2 Flange joints will be to AS 4087.
- 7.4.7.3 Where butt jointed pipes are used, the ends will be neatly butted where possible with a seal weld applied from the outside before the welding band is affixed. Steel pipes will be cut to a neat and true line with an abrasive saw.
- 7.4.7.4 After welding and testing (if required) all unprotected metal inside and outside will be thoroughly cleaned by appropriate methods.
- 7.4.7.5 The exposed steel will be protected promptly, and damaged protective coating repaired in an approved manner by the application of one of the treatments listed below:

- a) Emer-tan rust converter; Emer-guard primer; Emer-clad membrane; or
- b) Polyken Synergy™ which includes an appropriate primer coat; or
- c) Carbomastic 15 primer; Servi-Wrap R15A membrane; Servi-Wrap Outerwrap.

7.4.7.6 Joints will be internally protected with a mortar lining to give a smooth internal bore. Materials for the mortar will comply with the requirements of NZS 3121. It is important to get a satisfactory mortar consistency to prevent the mortar from sagging or dropping out.

7.4.7.7 The pipe joint will be plugged with a suitable plunger prior to applying the mortar and then withdrawn evenly to smooth out the mortar joint.

7.4.7.8 Epoxy mortar (suitable with potable water) will be used for making good the mortar lining where pipes have been cut for mitred joints, or the fitting of flanges etc.

7.4.8 Seismic Design for Pipes

7.4.8.1 All pipes and structure will be designed with adequate flexibility and special provisions to minimise risk of damage during earthquakes.

7.4.8.2 Historical experience in New Zealand earthquake events suggests that suitable pipe options, in seismically active areas, may include rubber ring joint PVC pipes, or PE pipes. Specially designed flexible joints will be provided at all junctions between pipes and rigid structures (such as reservoirs, pump stations, bridges, and buildings) in natural or made ground.

7.4.8.3 In areas prone to liquefaction or lateral spread, a geotechnical investigation will be required. The geotechnical investigation will need to assess the potential of the ground to liquefy under seismic loading and assess the likely effects of liquefaction on buried infrastructure. The assessment will be conducted in accordance with NZGS guidance: Guideline for the identification, assessment and mitigation of liquefaction hazards.

7.4.8.4 In areas where there is a potential for liquefaction or lateral spread to impact on buried infrastructure, the network must be designed with special provisions to minimise the risk of damage during an earthquake. Piped infrastructure is not generally designed for a particular seismic event but rather for optimum resilience under seismic loading.

7.4.8.5 All PE pipes will be jointed using butt welding or electrofusion technique. Electrofusion fittings will conform to AS/NZS 4129.

7.4.9 Watermains in Hydrocarbon Contaminated Ground

7.4.9.1 PVC pipes with EPDM or nitrile seal rings or solvent cement joints may be used in hydrocarbon contaminated ground.

7.4.9.2 PE pipes will not be used in ground that has been contaminated with hydrocarbons.

7.5 Fittings

This section sets out Council's requirements for pipe fittings, hydrants and valves.

Mandatory Matters

Council requires the following standards to be met in the choice and design of water supply fittings:

7.5.1 Pipe Fittings

- 7.5.1.1 Ductile iron fittings such as tees, hydrant tees, crosses, tapers, hydrant risers, blank caps, plugs and bends will conform to AS/NZS 2280, with thermo-bonded polymeric coating conforming to AS/NZS 4158. Ductile iron sockets for Elastomeric seal joints, used with PVC pipes will be “deep socket” type.
- 7.5.1.2 Tapping bands used on PVC pipes will be “full encirclement style” conforming to AS/NZS 4793.
- 7.5.1.3 Thermoformed PVC, elastomeric socket, long radius bends may be used with PVC pipes. and short radius (elbow) bends will not be used. Solvent cement bends may only be permitted where the necessary Z ring fitting is not manufactured.
- 7.5.1.4 On PE pipes DN 125 and larger, fittings will be end load resistant electrofusion or butt fusion style, to AS/NZS 4129.
- 7.5.1.5 Flanges will be to Table 9 of AS/NZS 4331.2 and AS/NZS 4087. Fittings laid adjacent to other fittings will have flanges.
- 7.5.1.6 All bolts, nuts and washers will be 316 stainless steel with molybond anti galling coating.
- 7.5.1.7 Graphite greases, packing and compounds will not be used in contact with stainless steel.
- 7.5.1.8 Where dissimilar metals are used, purpose-made delrin thermoplastic inserts will be installed in the flanges to prevent electrolytic action.
- 7.5.1.9 Fittings which do not have bolts, nuts and washers which are 316 stainless steel and/or fittings which are not thermos-bonded polymeric coated in accordance with AS/NZS 4158, will only be used at the Engineering Manager’s discretion where no alternative product is available. In this case these fittings will be wrapped as detailed in SD707 and SD708.

7.5.2 Corrosion Protection

- 7.5.2.1 These standards apply to the protection of flange and unrestrained mechanical couplings.
- 7.5.2.2 Protection will normally be provided by the use of 316 stainless steel bolts, nuts and washers and fittings coated to AS/NZS 4158. Fittings which do not have bolts, nuts, and washers that are 316 stainless steel and/or fittings which are not thermos-bonded polymeric coated will only be used with approval of the Engineering Manager.
- 7.5.2.3 Where metallic pipes and fittings are not coated Delrin thermoplastic inserts will be installed in the flange to prevent electrolytic action. Steel, grey cast iron and ductile iron flanges will be further protected by a wrapping system.
- 7.5.2.4 Corrosion protection will be required (as follows) for all new flange and unrestrained mechanical couplings, where materials other than 316 stainless steel and coatings to AS/NZS 4158 are used.
- 7.5.2.5 Flanges will comply with SD707.
- 7.5.2.6 Unrestrained Mechanical Couplings will comply with SD711 and AS/NZS 4998.

7.5.3 Hydrants

- 7.5.3.1 Fire hydrants will be installed on all principal mains in accordance with the requirements of the New Zealand Fire Service Code of Practice.
- 7.5.3.2 Hydrants must be readily accessible for fire appliances and should generally be positioned near road/street intersections in conjunction with valves.
- 7.5.3.3 A fire hydrant will be located at each road/street intersection and not be positioned closer than 6.0m from any dwelling.
- 7.5.3.4 In a cul-de-sac or other terminal streets, the last hydrant will be at the head of the cul-de-sac.
- 7.5.3.5 The distance between the hydrants and from the hydrants to the furthest building platform will not exceed 135.0m.
- 7.5.3.6 Should a fire hydrant be required to be provided on private rights-of-way, Engineering Manager's approval will be required. Council will require either an Easement In Gross in favour of Council over that line from the principal main to the hydrant or leave it as a private asset and have an isolation valve at the boundary.
- 7.5.3.7 Hydrants will be to NZS 4522. Normally the short pattern will be used, except where Council may approve or require the medium or tall pattern for extra flow capacity. Hydrants will not be self-draining. Hydrants will be blue nylon coated inside and out and be clockwise closing.
- 7.5.3.8 In some high-risk commercial areas, hydrants will be installed in pairs to provide better water flows (also refer Table 7-5).
- 7.5.3.9 Hydrant tees will be flanged if laid next to other fittings. Otherwise flexible Z ring joints are permitted, refer SD703.
- 7.5.3.10 Hydrant risers will be used or the water main laid deeper where necessary, in order to ensure that the top of the spindle is between 100mm and 200mm below finished surface level.
- 7.5.3.11 Hydrants will be installed so the spindle cap and riser connection are in line with the water main below.
- 7.5.3.12 The manufacture and installation of hydrant boxes will be to NZS 4522. Hydrant boxes will be aligned in the direction of the water main. Heavy pattern hydrant boxes will be used. All hydrant boxes (cover and frame) will meet Class D strength to AS 3996. Covers must be 'anti-rocking'.
- 7.5.3.13 Hydrants will be marked in accordance with SNZ PAS 4509 Appendix G. Hydrants will be marked in accordance with NZS 4501 with raised blue reflectorised markers together with painted triangle and painted fire hydrant box as shown on SD709.
- 7.5.3.14 Hydrant boxes will be set on approved pre-cast concrete sections.
- 7.5.3.15 The top of any surface box will be flush with the finished surface level in sealed carriageway and grassed surfaces. For areas to be planted, the top of the surface box will be between 40mm and 60mm above the finished surface level and no closer than 1.5m to trees or shrubs.

7.5.4 Positioning of Valves

- 7.5.4.1 Valves will generally be placed on all the three legs of a tee intersection to optimise control of the water supply system and minimise the number of customers without water in case of a shut-down.
- 7.5.4.2 Sluice valves will be flanged and bolted to each leg of the “tee” to form a single assembly. A hydrant will be included between the valves.
- 7.5.4.3 Line valves will be installed where the distance between other line valves exceeds 250m. For water mains over 200mm diameter, line valves will be required at least every 450m and will be positioned as agreed by Council. Rider mains will have valves at both ends, located as close to the principal main as practical, but within the berm or footpath.

7.5.5 Depth of Valves

- 7.5.5.1 The top of sluice valve spindles will be 200-300mm below ground level, refer SD704.
- 7.5.5.2 The top of the hand wheel on any resilient seated valve will be 150 to 225mm below ground level.

7.5.6 Sluice Valves

- 7.5.6.1 Sluice valves on all water reticulation will comply with NZS/AS 2638.2, Class PN16 (a class higher than 16 may be required in certain circumstances).
- 7.5.6.2 Valves will be resilient, seated, and anti-clockwise closing with a stem sealed by “o” rings capable of being replaced under pressure. They will have external and internal polymeric coating to AS/NZS 4158.
- 7.5.6.3 Specific design, subject to the approval of Council, will be required for valves over 250mm NB.
- 7.5.6.4 The valve will be capable of bi-directional flow of water. Valves will be set so that the spindle is truly vertical.
- 7.5.6.5 Sluice valves will be installed in accordance with SD704 and will be marked as per SD709.
- 7.5.6.6 Approval of any particular sluice or gate valve will be entirely at the discretion of the Engineering Manager.

7.5.7 Rider Main Valves

- 7.5.7.1 Valves on rider mains of 50mm internal diameter will be an approved resilient-seated sluice valve with socket ends. Where a valve is to be connected directly to a Tee, or similar flanged item, a valve with one flanged and one socket end is to be used.
- 7.5.7.2 Valves on other than PE rider mains of 50mm internal diameter will have connections suitable for the material used – socket/thread or flange as appropriate.

7.5.8 Air Release Valves

- 7.5.8.1 Water mains will be laid to grade such that, for the purpose of the release of the air, a fire hydrant, an automatic air valve or a 20mm diameter ferrule and gate valve in a permanent surface box will be installed at high points or in locations required by Council. They will be installed so that ground water cannot enter the main at negative main pressure.

7.5.8.2 Automatic air valves >25mm, will be approved testable, single or double, large or small orifice, and of appropriate nominal bore. Automatic air valves will be flanged and be mounted on flanged risers with an integral isolating valve accessible from ground level. Air valves that need to be installed below ground will be installed within a standard manhole (marked 'AV') with positive drainage to an outlet such that ground water cannot enter the main at negative mains pressure.

7.5.8.3 Automatic air valves should be installed above ground in all situations unless approved by the Engineering Manager.

7.5.9 Scour Valves

7.5.9.1 Scour valves will be either a fire hydrant or an approved resilient seated valve as for air release above and will be installed at low points or to facilitate draining of a water main where required by Council.

7.5.9.2 All dead-end mains or rider mains will be fitted with permanent scour valves complete with valve box.

7.5.9.3 In areas where the scouring of mains is needed as a frequent operation, a connection to an approved discharge point will be provided. The connection of a scour valve to stormwater pipes or manholes is not permitted.

7.5.9.4 The box will be similar to a fire hydrant box but will be marked "SV" rather than "FH".

7.5.10 Butterfly Valves

7.5.10.1 Butterfly valves will only be used with the specific approval of the Engineering Manager.

7.5.10.2 Butterfly valves will be located in concrete valve chambers.

7.5.11 Non-Testable Non-Return Valves

7.5.11.1 Swing check valves will comply with the relevant standards and AS 4794-2001.

7.5.11.2 Non-return valves will be capable of being serviced without removal from the main. Cast iron swing check valves will be fusion bonded thermoplastic coated or epoxy coated. All coatings will be compatible with potable water and will be coloured blue.

7.5.11.3 Below ground swing check valves will be within a standard manhole.

7.5.12 Valve Boxes

7.5.12.1 All valves will be fitted with an approved square pattern cast iron surface box with the lid marked "SV" or "V" and a 150mm lid on a PVC riser pipe. Heavy duty lids will be used.

7.5.12.2 The riser pipe will extend from the valve bonnet to 80mm below the finished surface and be placed vertically over the valve. The valve box will be supported on a firm foundation so that no direct loading is transmitted from the box to the main or riser, see SD703

7.5.12.3 If the distance between the finished surface level and the top of the valve spindle is greater than 300mm, a valve key extension will be fitted.

7.5.12.4 Valve boxes will be painted as shown in SD709.

7.5.13 Restraint blocks

- 7.5.13.1 Cast in-situ concrete restraint blocks will be provided on mains 50mm ID or greater, at all points where an unbalanced thrust occurs. This will include all bends, tapers, valves, pressure reducing valves, tees and blank ends.
- 7.5.13.2 For butt welded and electrofused PE pipework up to 150mm ID, restraint blocks may not be required. Where PE pipes connect to other pipework or fittings with flexible joints, restraint blocks are required.
- 7.5.13.3 The design of restraint blocks will be based on “good ground” soil bearing capacity (as defined in NZS3604) or the ultimate bearing capacity of the site soils, whichever is lesser. A safety factor of between 1.5 and 2 will be used in the design. Restraint block bearing area calculations will be submitted with the engineering plans for checking and approval.
- 7.5.13.4 The inner face of the block will not be of a lesser thickness than the diameter of the fittings and will be so constructed as not to impair access to the bolts on the fittings. Concrete will have a minimum compressive strength of 25mPa at 28 days.
- 7.5.13.5 All restraint blocks will be cast in-situ concrete. Pre-cast concrete blocks may be permitted with the Engineering Manager approval.
- 7.5.13.6 A protective membrane of not less than three layers of 250 micron polythene sheet or similar will be provided between the pipe (irrespective of the pipe material) and the concrete block to prevent abrasive damage to the water main.
- 7.5.13.7 Valves and hydrants on PVC pipe lines require anchorage to resist torque when the valve is operated.
- 7.5.13.8 Valves will be anchored as shown on SD704. A fish-tailed galvanised flat steel bar will be attached to the bottom bolt on each flange of the valve and incorporated into a cast in-situ concrete pad 200mm deep, of the same width as the trench and extending 150mm beyond each anchor bar. Care will be taken to ensure that all bolts can be removed for future maintenance and are not obstructed by concrete.
- 7.5.13.9 Hydrant tees, when flanged, will be anchored as valves, refer SD704. Hydrant tees with rubber ring joints will be anchored by bedding the tee in a concrete pad 200mm deep, of the same width as the trench and not extending beyond the length of the tee. Care will be taken to ensure that the flexible joints are not encased.

7.5.14 Thrust Block design

- 7.5.14.1 In designing water main restraint blocks, the following formula will be used:

Bends:

$$\text{Thrust Force } R = 15.4 H d^2 \sin (\theta/2)$$

R = thrust in kN

Where H = head of water in metres, i.e. 180m max

d = diameter of pipe in metres

θ = angle of deflection Pipe dia - d	θ -11.25° bend	θ -22.5° bend	θ -45° bend	θ -90° bend
100	2.77	5.51	10.81	19.98
150	6.23	12.40	24.33	44.96
200	11.08	22.05	43.26	79.93

R – thrust in kN for each diameter and bend.

Tee or Closed End:

$$\text{Thrust Force } R = 7.7 H d^2$$

R = thrust in kN

Where H = head of water in metres, i.e. 180m max

d = diameter of pipe in mm

Reducers:

$$\text{Thrust Force } R = 7.7 (d_1^2 - d_2^2)$$

R = thrust in kN

Where H = head of water in metres, i.e. 180m max

d1 and d2 are the two pipe internal diameters in mm. The magnitude of this thrust can be obtained by taking the difference of the two thrusts for closed ends of the two relevant diameters.

Table 7-6 Pipe Thrust Block Design

	Pipe diameter	Face area m2 or m3	11.25° Angle of deflection	22.5° Angle of deflection	45° Angle of deflection	90° Angle of deflection
Vertical downward thrust	100	m2	0.09*	0.09*	0.09*	0.13
	150	m2	0.09*	0.09*	0.16	0.30
	200	m2	0.09*	0.15	0.29	0.53
Vertical upward thrust	100	m3	0.17	0.34	0.68	1.25
	150	m3	0.39	0.74	1.52	2.81
	200	m3	0.69	1.34	2.70	5.00
Horizontal sideways thrust	100	m2	0.12	0.23	0.45	0.83
	150	m2	0.26	0.52	1.02	1.88
	200	m2	0.46	0.92	1.81	3.34

Note:

- 1) *Minimum restraint block size 300 x 300 x 300;
- 2) Table 7-6 is a guide only;
- 3) Soil parameters are classed as “good ground” in accordance with NZS 3604;

- 4) Test head 150m and factor of safety of two (2) for all applications.

7.6 Water Supply Connections

This section prescribes standards for the provision of supply connections.

Mandatory Matters

Council requires the following standards to be met in the provision of supply connections

7.6.1 Point of supply to customer

- 7.6.1.1 The point of supply to each customer will be determined in accordance with the Council's Water Supply Bylaw. Each individual dwelling or unit will have a single point of water supply and a meter. Premises of multiple ownership including body corporate, strata title and leasehold/tenancy in common scheme will be supplied and metered in accordance with the Council's Water Supply Bylaw.
- 7.6.1.2 Individual lots will have individual meters located at the street boundary. From the meter an individual water connection will be installed to the body of each individual lot.
- 7.6.1.3 In all situations the meter box is to be located a minimum of 0.5 m clear of the driveway entrance and not located within the driveway.

7.6.2 Service Connection Diameter

- 7.6.2.1 The standard connection sizes must be 20mm ID, 25mm ID, 40mm ID, 50mm ID, 100mm ID and 150mm ID. Any connection larger than this will need to be approved by the Engineering Manager.
- 7.6.2.2 The minimum size will be 20mm internal diameter to urban connections.
- 7.6.2.3 The minimum size connection to a commercial/industrial lot is 50mm internal diameter.

7.6.3 Individual Connections

- 7.6.3.1 An individual connection will be required for each lot via its own legal street frontage with the meter assembly located at the street boundary. For clarification - back sections served by rights of way need to have their own individual water meter located at the street frontage. Individual water connections (owner and maintained by the individual land owners) are to be provided from the meter to the rear lots.
- 7.6.3.2 Where tapping bands and service connections are to be omitted in commercial and industrial subdivisions (with the approval of the Engineering Manager), a covenant will be placed on the title outlining that the lot owner is responsible for all costs associated with the installation of the service connection (all costs include development contributions physical installation and related fees).
- 7.6.3.3 All service connections will be laid at right angles to the frontage. The supply line between the ferrule and the meter box is to be laid as a single length of pipe with no joins or tight bends along its length.

7.6.4 Tapping Bands and Ferrules

- 7.6.4.1 Tapping bands for PVC pipes will comply with AS/NZS4793.

- 7.6.4.2 Tapping bands for PE pipes will be specifically designed for use with PE pipe and comply with AS/NZS 4129. Bronze mechanical tapping saddles will not be used on PE pipes.
- 7.6.4.3 Where the horizontal distance between the ferrule and the meter manifold is less than 1.0m, the assembly will be subject to specific design approval by the Engineering Manager and will be laid to avoid any pipe stresses.
- 7.6.4.4 In all situations, lateral connections and ferrules will be located a minimum of 0.5m clear of driveway entrances.
- 7.6.4.5 Each service connection to a main or a rider main will be by means of a tapping band and a "Talbot" Bronze push-fit swivel ferrule with the flow of water controlled by a screwed brass plug.
- 7.6.4.6 Tapping bands on PVC pipes will be of an approved type complying with AS/NZS 4793, fully encircling the pipe to prevent over tightening and distortion of the pipe.
- 7.6.4.7 Tappings on ISO dimension PE80 - pipes will be by means of a vertical compression tee (with BSP female branch) and ferrule. Tapping saddles will not be used on PE pipe without approval by the Engineering Manager.
- 7.6.4.8 If the required service is larger than is possible to connect with a tapping band the main connection will be by a tee or a tapped elongated joint having a vertically connected ferrule. For connections, larger than 50mm ID, the connection will be by means of an elongated gibault tee and sluice valve at the approval of the Engineering Manager.
- 7.6.4.9 Tapping bands and ferrules on the water mains will be fitted when the mains are first laid (except as provided for in Section 7.6.4).

7.6.5 Meter Assembly for 20mm and 25mm ID Connection

- 7.6.5.1 The service connection will terminate adjacent to the street boundary with an approved 20/25mm nominal bore water meter assembly and box approved by the Engineering Manager. All meter assemblies must consist of a manifold, isolating valve and double check valve housed in an "Everhard", Acuflo AMBT285, or "Draper" DRA 20/1 underground meter box. Metal meter boxes are to be used for commercial and industrial accessways and in residential areas that will be traffic loaded and with the approval of the Engineering Manager.
- 7.6.5.2 The meter box will be no closer than 150mm or more than 300mm away from the street boundary on the street side of the boundary, clear of regular vehicle traffic movement.
- 7.6.5.3 The pipework at the meter box will have an earth cover of 260mm to 300mm depth over it. Refer SD706 and finished flush with the surrounding ground.
- 7.6.5.4 The meter box will be placed on a firm base so that it will not be depressed below the finished surface by settlement or occasional vehicular traffic.

7.6.6 Meter Assembly for 32 - 40mm ID Connection

- 7.6.6.1 For 32 – 40mm ID services a meter assembly consisting of an approved resilient seated valve with stainless steel bolts will be used. The meter will be approved by the Engineering Manager. An approved backflow preventer will be used with the meter and housed in an approved meter box or above ground if testable.

7.6.7 Meter assembly for 50mm ID and larger Connection

7.6.7.1 All service connections including dedicated fire sprinkler or fire-fighting mains will be required to be metered.

7.6.7.2 The meter will be a compound meter and will be approved by the Engineering Manager and will be installed at the boundary to the manufacturer's specification and housed along with approved isolating valve and backflow preventer in a meter box of size and construction approved by the Council. If a reduced pressure zone backflow preventer is used, this will be mounted above ground level. Meters other than compound meters require specific approval for installation at new sites.

7.6.8 Water Meters

7.6.8.1 At the completion of works and prior to issue of the 224 certificate for developments, the Developer must supply a completed water meter location form (see Appendix A) to the Engineering Manager for approval. Water meters will be fitted to all connections in accordance with Table 7-7.

Table 7-7 Approved Water Meters and Meter Boxes

Connection Size, ID (DN) (mm)	Meter Size (mm)	Meter Designation	Average Flow (m ³ /hr)	Maximum flow (m ³ /hr)	Meter Class	Meter Type	Meter Model
20 (25)	20	Qn 1.5	1.5	3.0	Q ₃ 2.5 R160 (C)	Manifold	Must be approved by the Engineering Manager
25 (32)	20	Qn 1.5	1.5	3.0	Q ₃ 2.5 R160 (C)	Manifold	
25 (32)	25	Qn 3.5	3.5	7.0	Q ₃ 6.3 R160 (C)	In line	
40 (50)	40	Qn 15	15	45	Q ₃ 25 R315 (C)	In line	
50 (63)	50	Qn 15	30/35	50	Q ₃ 25 R315 (B/C*)	Compound	
100	80	Qn 40	40	80	Q ₃ 63 R315 (B/C*)	Compound	
	100	Qn 60	60	120	Q ₃ 100 R315 B/C*	Compound	
150	100	Qn 60	60	120	Q ₃ 100 R315 B/C*	Compound	
	150	Qn 150	150	300	Q ₃ 250 R315 B/C*	Compound	

* = for compound meters; high flow meters Class B, low flow meters Class C;

Note:

- 1) Meters with higher "R" numbers are acceptable. Compound meters are designated by the characteristic of the larger meter only;

- 2) Meter connections larger than 25 mm diameter will be subject to the approval of the Council. The applicant may be required to present hydraulic calculations supporting the choice of meter size to the Council for approval.

7.6.9 Backflow Preventers

- 7.6.9.1 All new industrial and commercial properties will have a backflow preventer installed after the meter as close as practical to the point of supply. The type and location of backflow preventers will comply with the Building Act, the Health Act 1956 as amended by the Health (Drinking Water) Amendment Act, AS/NZS 2845.1 and the Council's Water Supply Bylaw.

7.6.10 Reuse of Existing Service Connections

- 7.6.10.1 A proposal to reuse an existing service will only be approved if the service is of adequate size; and, it can be established that the service is less than 15 years old; or, the service is to continue supplying the same building that it was originally intended for, and no others.
- 7.6.10.2 This policy applies only to the Council portion of the water service i.e. from the main up to the point of supply.

7.6.11 Disconnections

- 7.6.11.1 Redundant services will be disconnected from the water main by Council's approved contractor.
- 7.6.11.2 The service fitting will be removed or plugged at the connection to the water main.
- 7.6.11.3 All costs associated with the disconnection will be recovered by Council from the landowner requiring the disconnection.
- 7.6.11.4 Meter box, manifold assembly and meter will be removed. These remain the property of Council.
- 7.6.11.5 A final meter reading will be recorded and supplied to Council.

7.6.12 Fire Sprinkler Supply

- 7.6.12.1 A domestic fire sprinkler supply will come off the Individual water supply after the Council's water meter assembly, see SD706.
- 7.6.12.2 Commercial fire sprinklers systems will require specific design and require a separate metered connection. All above ground valves will be suitably protected from vandalism or accidental damage.
- 7.6.12.3 Designs for fire sprinkler and reticulation will allow for pressure reductions due to backflow prevention devices.
- 7.6.12.4 Fire sprinkler supply connections may require combination metering.
- 7.6.12.5 Fire sprinkler system as a means of compliance with the New Zealand Fire Service Fire Fighting Water Supplies Code of Practice will require a Notice to be registered on the land title setting out the requirements of the landowner for ongoing maintenance of the system and a condition entered in the Council's database accordingly.
- 7.6.12.6 Council's compliance with the code of practice relating to fire-fighting is detailed in section 7.3.9.

Good Practice

The following matters provide additional direction and guidance in the design of supply connections:

7.6.13 General

7.6.13.1 Regarding service connection materials, ISO dimension PE80 pipes to NZS 4130 are normally technically adequate.

7.6.13.2 Council does not allow the use of copper pipe.

7.7 Pumping and Storage

This section deals with standards and good practice matters relating to pumping and storage aspects of the water supply network.

Mandatory Matters

Council requires the following standards to be met in the design of pumping and storage solutions:

7.7.1 Pump Station Design

7.7.1.1 Pump stations will comply with Council's requirements and these specific designs are updated on a regular basis. Design will be dependent on a number of factors and should be discussed with the Council at an early stage.

7.7.1.2 New pumping stations will only be accepted by Council when all other practical options have been ruled out.

7.7.1.3 Design of the pumping station will enable operation of the station in compliance with industry health and safety requirements having particular regard to safety from falling aspects on site and confined space entry.

7.7.1.4 In all pumping stations, the following design specifications apply:

- a) Sufficient duty pumping capacity will be available to handle the design peak flow within a pumping period of 12–15 hours;
- b) A minimum of two pumps will be installed, with one acting as duty pump and the other on automatic standby. The duty sequence is to be alternate start on variable speed drives in accordance with Council control system standards. The standby pump will be equal in capacity to the duty pump;
- c) Ground floor levels will be at least 200mm above finished ground levels in order to exclude surface water entry;
- d) All pump station site structures will be designed for a minimum 100-year life complying with the building code;
- e) All electrical systems need to be radio frequency neutral, isolated or complying with Central Government radio frequencies standards;
- f) The structure needs to meet seismic resilience level of importance 3.

7.7.2 Access and Services

- 7.7.2.1 Pumping stations and control buildings will be sited on a separate lot or a utility reserve. The lot is to be vested in Council and will have a sealed access road for maintenance vehicles. The site as a minimum should have screen planting on all common boundaries that will not exceed 2m in height on the South boundary.
- 7.7.2.2 A means of lifting pumps and other heavy equipment, or alternatively access to enable mobile plant to perform this task is to be provided on site.
- 7.7.2.3 An approved flow meter will be installed on the outlet line from the pump station and connected to the telemetry system.

7.7.3 Electrical Equipment

- 7.7.3.1 An electrical pump control, alarm, and telemetry system is required on site. It will be assembled and installed in accordance with Council's standard specification.
- 7.7.3.2 A stainless-steel control cabinet is required to house electrical equipment. Cabinets are to be fitted with a lock keyed to Council's security system.
- 7.7.3.3 All electrical switch gear is to be located a minimum of 300mm above ground level. All electrical equipment is to be assembled and installed in accordance with these standards or the manufacturer's specifications.
- 7.7.3.4 All equipment including metering must comply with the requirements of the Network Utility operator and supplier (power).
- 7.7.3.5 Suitable alarm and system control interrogation and transmitting facilities will be provided to enable the pumping stations to be connected to Council's telemetry system.
- 7.7.3.6 Cable ducting from the pump station to the control cabinet must be sealed to protect against vermin entering the electrical switchboard.
- 7.7.3.7 All electrical and pump station control gear including telemetry will be housed within a weather proof, lockable, walk-in building to Council approval.
- 7.7.3.8 Phase failure protection relays will be provided for all pump motors unless that protection is incorporated into the electronic control for Soft Start or Variable Speed Drive units.
- 7.7.3.9 Automatic control of the pump operation, together with a manual override facility is to be provided.
- 7.7.3.10 A standard three-phase industrial power connection will be supplied such that a portable generator can be connected when power failure occurs.
- 7.7.3.11 Suitable lighting inside buildings and outside will be provided for the pump station, cabinets and valve chambers with protective materials suited to the external environment.
- 7.7.3.12 Details on pump/motor components and electrical control equipment will be incorporated into an Operation and Maintenance Instruction Manual provided in electronic format.
- 7.7.3.13 The Manual will include as-built plans of the pump station including electrical wiring and operational schematic diagrams. Electronic copies of the Manual will be supplied to Council on handover of the completed pump station and associated works.

7.7.3.14 Any digital data/ programs relating to variable speed drives and starting equipment must be given to Council digitally at the time of commissioning and included in the Operations and Maintenance manuals.

7.7.3.15 All electrical systems need to be radio frequency neutral, isolated or complying with Central Government radio frequencies standards.

7.7.4 Commissioning

7.7.4.1 On completion of any pump station, and prior to handover to Council, a full commissioning test will be carried out on all components of the pump station. This commissioning will be in the presence of a representative of Council and of Council's operations and maintenance contractor.

7.7.5 Reservoir Requirements

7.7.5.1 Small individual reservoirs are not permitted.

7.7.5.2 If a developer needs to construct a reservoir as part of a development, discussions must occur with the Engineering Manager regarding the specific needs for that catchment. This may result in the Council working with the developer to optimise the reservoir design and location.

7.7.6 Security of Water Supply Facilities

7.7.6.1 The developer will provide temporary locks on all doors, lids, chamber covers and gates that require limited access for operational or security purposes.

7.7.6.2 Appropriate locks will be ordered through Council and fitted to facilities prior to application for 224 certification. The developer will be responsible for all costs associated with the supply and fitting of locks.

7.7.6.3 Once Council locks are fitted to water supply facilities only Council or their maintenance contractor and engineering consultancy staff will have access to the equipment.

7.7.6.4 Council's maintenance contractor will assume responsibility for routine maintenance of the asset but any work arising from failure of equipment or materials, or faulty workmanship will be on-charged to the Developer during the prescribed defects maintenance or guarantee period.

7.7.7 Private Pumping Stations

7.7.7.1 Individual, private pump systems are permitted provided the design and construction meets the requirements of the NZ Building Code (a Building Consent will be required) and the connection to the Council system is via a water meter and backflow protection to a suitable sized water tank located on the private land. There is to be no direct pumping from a water connection.

7.8 Construction and Installation

This section sets out Council's expectations for the installation and construction of the water supply network.

Mandatory Matters

Council requires the following standards to be met in the construction and installation of water supply reticulation:

7.8.1 Trench Width

- 7.8.1.1 The minimum trench width will be 200mm wider either side than the external diameter of the collar of the pipe being laid.
- 7.8.1.2 The trench will be of sufficient width to permit with freedom the installation of all trench support and to allow the laying and jointing of pipes and placing of bedding and pipe surround materials.

7.8.2 Base of Excavation

- 7.8.2.1 No construction or work above the excavation base will commence until the base of the excavation has been inspected and accepted by the DPA. The trench base is to be checked for stability of the soil by the DPA.
- 7.8.2.2 The Contractor will provide trench support to comply with the requirements of Work Safe New Zealand.

7.8.3 Trench Support

- 7.8.3.1 The Contractor will ensure that the sides of the trench are sufficiently supported so that cracking of the surrounding ground does not occur.

7.8.4 Trench Foundation Stability

- 7.8.4.1 Where there are issues concerning foundation compaction and stability, the DPA will order the use of additional granular bedding material as specified in AS/NZS 3725 for concrete pipes, or AS/NZS 2566.2 for PVC and other flexible pipe systems.

7.8.5 Dewatering

- 7.8.5.1 Excavations will be kept free of water during construction.
- 7.8.5.2 In no circumstances will stormwater or ground water be allowed to drain into any existing wastewater drain.
- 7.8.5.3 Discharge of stormwater or groundwater to existing stormwater drains will be permitted providing adequate silt traps prevent debris and suspended matter from entering drains. Should deposits in existing stormwater drains or the pipes already laid occur as a result of the operations of the Developer or the Contractor such deposits will be cleared forthwith at the Developer's or the Contractor's cost as the case may be.
- 7.8.5.4 The Contractor or Developer will cause as little damage or interference to property or persons as possible in disposing of water from the works, and will be responsible for any damage or interference, which may be caused. This will include any damage to the structure of any road.

7.8.6 Metal Bedding

- 7.8.6.1 The standards apply in respect of bedding, haunch support and side support material as defined by NZS 2566.2: and AS/NZS 3725.
- 7.8.6.2 Metal bedding will be in accordance with SD614 and SD615.
- 7.8.6.3 The bedding material will be:

- a) In a sand environment – use compacted saturated sand;
- b) For PVC and flexible pipes - AP20 NZTA M4 or as per AS/NZS 2566.2;
- c) Bedding compaction will be undertaken in accordance with AS/NZS 3725 for type H2 support;
- d) The pipes will be laid and brought to true alignment and level before installing the metal haunching, side support and covering the pipes.

7.8.7 Pipe Embedment

- 7.8.7.1 The metal haunching and side support will be placed uniformly along and around the whole length of the pipe barrel, couplings and other appurtenances in a manner to ensure uniform density of side support (including haunch support) and overlay with no distortion, dislodgement or damage to the pipeline.
- 7.8.7.2 Following placement, the embedment material will be compacted in layers to uniformly support the pipe. When choosing compaction equipment, the number of passes and the thickness of layer to be compacted, account will be taken of the material to be compacted and the pipe to be installed.
- 7.8.7.3 Compaction equipment or methods that produce horizontal or vertical earth pressures that may cause damage to, or excessive distortion of, the pipe will not be employed.
- 7.8.7.4 Metal haunching and side support will be compacted to the manufacturer's requirements and as a guide, a minimum Clegg Impact Value of 35 under vehicle loaded areas or 25 under non-traffic loaded areas will be achieved at any point on any haunching constructed of AP20.

7.8.8 Geotextiles

- 7.8.8.1 Where there is a possibility of migration of fines between the native soil and the pipe surround soil, the DPA will require the metals to be protected by an approved geotextile filter fabric that overlaps by at least 300mm. The extent of this "geotextile wrapping" must be shown on the as-built plans.

7.8.9 Concrete Protection

- 7.8.9.1 Where cover over pipes is less than the minimum as required by the pipe manufacturer and the relevant New Zealand standards, including temporarily under construction traffic, a concrete protection slab will be constructed. The written approval of the Engineering Manager is required for all concrete protection.

7.8.10 Water Stops and Trench Groundwater

- 7.8.10.1 A specific design is needed where permeable bedding is used. Water-stops and trench drainage will be constructed to prevent unwanted movement of groundwater along the trench and pipe bedding, see SD613 (Chapter 6). All captured stormwater must be reticulated to the stormwater network, or at least an approved stormwater outlet.
- 7.8.10.2 Manholes will be considered to be water-stops provided they are constructed appropriately.
- 7.8.10.3 Where water stops are required, they must be provided at the intervals set out in
- 7.8.10.4 Table 7-8.

Table 7-8 Water Stops Spacing and Gradient

Grade	Spacing
1 in 15 or steeper	12m
1 in 15	15m
1 in 25	30m
1 in 100	60m

Note: Intermediate grades (and spacing) are determined by interpolation.

7.8.11 Pipe Installation

7.8.11.1 In respect of pipe installation, Pipes will not be laid on bricks, blocks and wedges or other temporary or permanent supports.

7.8.11.2 Pipes will be kept clear of dirt or debris, and any pipes that contain such matter will be required to be cleaned out. Internal pipe walls will be kept clean and free of all dirt, rubbish and water. Spigots, sockets, rubber rings, fittings etc, will be thoroughly cleaned before jointing.

7.9 Trenchless Technology

This section relates to the use of trenchless technology for the installation of water reticulation.

Mandatory Matters

Council requires the following standards to be met in the use of trenchless technology for the installation of water reticulation:

7.9.1 General

7.9.1.1 Trenchless technology will only be used in specific circumstances where approved by the Engineering Manager.

7.9.1.2 Pipes used for trenchless installation will have suitable mechanically restrained joints, specifically designed for trenchless application, which may include integral restraint, seal systems, or heat fusion welded joints.

7.9.1.3 Any trenchless technology and installation methodology will be chosen to be compatible with achieving the required gravity pipe gradient – refer to the manufacturer's and installer's recommendations.

7.9.1.4 The following details including location of access pits and exit points will be submitted to the Engineering Manager for approval:

- a) Clearances from services and obstructions; the depth at which the pipeline is to be laid to ensure minimum cover is maintained;
- a) The pipe support and ground compaction;
- b) How pipes will be protected from damage during construction;
- c) Any assessed risk to abutting surface and underground structures; and
- d) A clear methodology of how to deal with unknown obstructions and services.

- 7.9.1.5 Gouging or notching of the pipe will not exceed 10% of the pipe wall thickness for pressure pipe and 20% of the pipe wall thickness for gravity pipe. Pipe will not be bent to a radius less than 35 times the pipe OD for PE pipes or 600 times the pipe OD for PVC pipes.
- 7.9.1.6 The specified allowable load on the pipe will not be exceeded during pulling.
- 7.9.1.7 Where gouging or notching exceeds the above limits or if buckling of the pipe occurs, that length of pipe will be removed, and a new section welded in at the nearest join.
- 7.9.1.8 The contractor will over tow the pipe by one lineal metre for each length of pulled pipe that is the greater of one manhole length or 200m. The excess pipe length will be supplied to the DPA for a visual inspection.

7.9.2 Tracer Tape

- 7.9.2.1 For water work a tracer tape system must be incorporated into the trenchless work. The tracer tape must comply with section 7.9.4.
- 7.9.2.2 The location of all water mains will be marked with a foil tape buried in the trench.
- 7.9.2.3 The tape will be blue, 50mm wide, and printed with "CAUTION WATER MAIN BURIED BELOW" or similar message. All printing will be encased to avoid rub-off.
- 7.9.2.4 The tape will be either a woven reinforced acid and alkali resistant polythene plastic with a solid aluminium foil core which will be visible from both sides.

7.9.3 Tracer Tape Installation

- 7.9.3.1 The tape will be buried above the centre line of the pipe within 300mm to 400mm from the finished surface, refer SD702.
- 7.9.3.2 All joints in the tape (e.g. roll ends, accidental breaks and at tees) will be made electrically conductive with purpose made splice clips installed to the specific manufacturer's instructions. Tying together of the tape ends is not acceptable as the polythene coating will prevent electrical conductivity.
- 7.9.3.3 The tape will be brought up inside the surface box risers at all valves and hydrants with a 300mm long tail so that pipe location equipment can be readily connected.

7.9.4 Tracer Wire

- 7.9.4.1 When a pumping main or swallow pipe is installed by a directional drilling technique or bored through the ground for a distance exceeding 20 metres a specific design for traceability is required.

7.9.5 Tape or Wire Testing

- 7.9.5.1 The tracer tape will be tested by the Contractor for continuity using an electric pulse induction system. The test must be witnessed and approved by Council.
- 7.9.5.2 The new watermain/rider main will be tested between any new valves, hydrants etc where the tape is brought up inside the surface box risers. This test will only be undertaken when all work associated with laying the watermain/rider main is complete.

7.9.6 Testing, Disinfection and Connection

- 7.9.6.1 All water supply pipelines to be vested in Council ownership and/or connected to the Council network will pass the hydrostatic pressure test in NZS 4404 Appendix C3 'Pressure pipelines – Field hydrostatic pressure testing'. All final test results sheets are to be included in the package of as-built information provided to Council.
- 7.9.6.2 All new reticulation will be flushed and disinfected to the requirements of NZS 4404, Appendix D – 'Water Supply Disinfection Specification'.
- 7.9.6.3 Connection to existing water main will not be made until all new work (excluding the connection) has been completed and inspected and approved by Council. Specifically, this will include testing, disinfection and flushing of all new pipework, and fittings by the Contractor.
- 7.9.6.4 The developer is to consult with Council as to the requirements of the flushing and disinfection of all new water reticulation. Disinfection of the new water reticulation needs to ensure that there is no *E. coli* and acceptable levels of coliforms in the sourced water. Testing will be on a case by case basis depending on the pipe network size and length of pipe. Council will carry out the final testing etc to determine if the required disinfection has been carried out.

Note:

If *E. coli* re-testing is required by the Council, the costs may be on-charged to the Developer.

Good Practice

The following matters provide additional direction and guidance in the construction and installation of water supply reticulation:

7.9.7 Trenching

- 7.9.7.1 A plate compactor is to be run over the trench floor to bind the surface and identify any obvious weak spots. Where the bottom of an excavation is unable to provide a firm foundation with minimum bearing capacity of 50kPa (e.g., clay soils that can easily be penetrated 40mm with a thumb or in sand or gravel that makes a footprint more than 10mm deep) at the required level without abrupt irregularities, engineering advice should be sought on how to provide a satisfactory foundation (see AS/NZS 2032, clause 5.3.6).
- 7.9.7.2 Where trench support extends below the invert of the pipeline or structure special precautions may be required, including leaving part of the support in place, to ensure the foundation of the pipe or structure is not weakened.
- 7.9.7.3 Ground water lowering may be permitted except where this practice may present a risk of subsidence. Resource consent may be required.

Appendix A Water Meter Location Form

Tasman District Council
 Private Bag 4
 Richmond
 Nelson 7050

To: Water Meter Officer

Subdivision/Meter Location

Resource Consent No. _____ (If applicable).

The following table defines information required by the Council for all new water meters.

- 1) In the Meter Type Column please indicate whether the meter is a Sensus 620M or Elster (Kent) V120 water meter. Indicate either S or E.
- 2) In the Meter Reading Column show the reading to the nearest whole cubic meter only (BLACK NUMBERS on the meter).
- 3) In the Location Column, indicate whether the measurement is from the right or left boundary when facing the lot from the road (R or L) Show one measurement to the meter from either the right or left boundary (measured along the front boundary) and one measurement to the meter from the front boundary (measured perpendicular to the front boundary).

Lot No	D.P No.	Street No.	Street Name	Meter Type S or E	Meter No.	Meter Reading (m3)	Reading Date	Location (Distance from)		
								R/L	Side Bdy (m)	Front Bdy (m)

Lot No	D.P No.	Street No.	Street Name	Meter Type S or E	Meter No.	Meter Reading (m3)	Reading Date	Location (Distance from)		
								R/L	Side Bdy (m)	Front Bdy (m)

(Use additional page if required)

Name: _____

Signature: _____ Date: _____

Address: _____

Appendix B Rural Water Supply – Tasman District Council only

Council operates low-flow rural water supplies outside urban centres over large sections of the Waimea and Moutere areas. Many of the pipelines (laid with the permission of the “then” owner) serving these schemes are not protected by easements but cross large tracts of private land. Connection to some of the schemes are limited by pipeline capacity, water permits conditions and by allocation limits established in the TRMP.

B.1 Connection to Existing Rural Water Supplies

B.1.1 When contemplating subdivisions or development in rural areas, Designers should first ascertain the existence of a water supply reticulation system in the area. Should one exist, the Developer or subdivider will require confirmation from Council that capacity for connection is available if required.

B.1.2 Designers will need to:

- i) Consult the New Zealand Fire Service for cluster developments, to satisfy SNZ PAS 4509.
- ii) Demonstrate that capacity is available for proposed and foreseeable future flows, and
- iii) Verify that an easement for a pipeline can be secured.

B.1.3 Written confirmation of the above will be attached to the subdivision consent application.

B.2 Relocation of Rural Supply Pipelines

B.2.1 Where any development requires relocation of rural water supply pipelines the cost of relocation and the easement will be a charge against the Developer. All relocated pipework located within private property will need to be protected by way of an easement in favour of Council (Note 7.3.11.3). No relocation of a water supply can take place without the approval of Council.

B.3 New Rural Supply

B.3.1 If no public rural water reticulation schemes are available for connection, the consent holder will prove that at least 1.0m³ of potable water per day per lot is available to serve the subdivision. Easements may be required to the water source to secure the supply. (Due to the lack of consistent rainfall in the Tasman area, roof water supply alone cannot be relied upon to service the subdivision). Also an approved water take may be required as set out in the TRMP.

B.4 Rural Connections

B.4.1 Each lot will be serviced by a minimum 20mm diameter service pipe with a restrictor valve as approved by Council to limit supply.

B.4.2 Where water is available, reticulation will be installed and the consent holder will pay the applicable fee for joining and connection of each lot. Joining fees for each scheme together with charges are set out in Council’s LTP.

B.4.3 Storage of water on a rural water scheme must comply with Council’s Water Supply Bylaw.

B.5 As-Built Drawings

B.5.1 The developers will, whether or not connections are made to the rural scheme, provide as-built plans of the position of rural water supply pipelines relative to the boundaries within the development.

B.6 Rural Fire Fighting Supply

B.6.1 For any dwelling that is not connected to a reticulated water supply incorporating water mains fitted with fire hydrants, with the closest hydrant no more than 135m from the dwelling, it is a requirement of the TRMP (refer Chapter 17) that each dwelling will have either a home fire-sprinkler system that is fitted with a reliable year-round water supply OR;

- B.6.2 The dwelling will have access to a water supply of at least 45,000 litres provided in an approved location solely for fire-fighting purposes. The water must be accessible to fire-fighting equipment. Any water storage must be full at all times.
- B.6.3 The fire-fighting water supply can be from a number of sources; dams, water tanks, pools and lakes, streams and rivers, sea water.
- B.6.4 A fire appliance should be able to sit on a hard-standing area and be no more than 6.0m from the water source (or water supply connection). The water source should be no more than 3.0m below, and no more than 10.0m above the appliance pump inlet.
- B.6.5 A fire service coupling will be required to enable access to the water supply. Appropriate all-weather access for a two-axle truck should be provided to the supply site.

In cluster housing developments in rural supply areas fire-fighting water supplies may be combined. This may include a group of linked tanks above house levels and sited to mitigate visual impact on the landscape (as an alternative to individual tanks on each property). These tanks may be fed from the rural restrictor supply and/or from roof supply and pumps. Easements or consent notices may be required to protect these reservoirs and lines for the lots they serve. These will be provided with access, reticulation (a minimum 100mm diameter main), fittings for fire-fighting purposes and a hard-standing area reserved for fire appliances. The fire service couplings will be no further than 90.0m from, and no closer than 6.0m to the dwelling.

- B.6.6 Further advice and information about managing fire risk and storage of water for fire-fighting, including information about appropriate fittings for connection with fire appliances, can be obtained from the New Zealand Fire Service.

LEGAL ROAD

APPROVED

APPROVED

RIGHT OF WAY / COMMON ACCESS

EXCLUSIVE DRIVEWAY

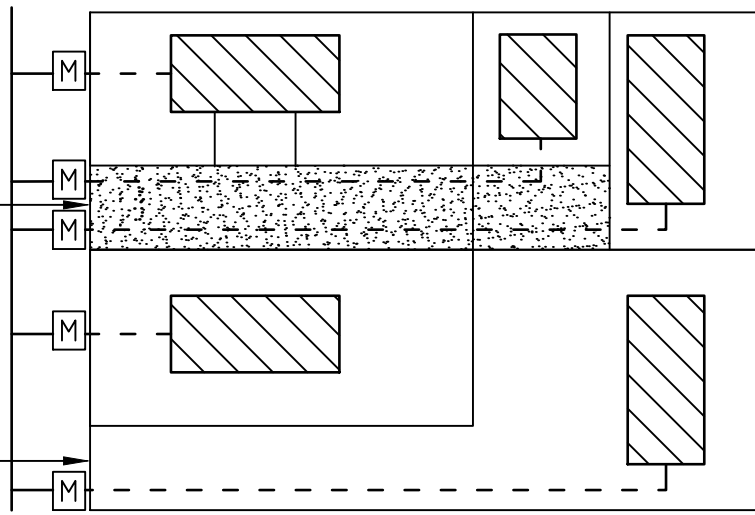

LEGAL ROAD

NOT APPROVED

NOT APPROVED

NOT APPROVED

NOT APPROVED

EXCLUSIVE DRIVEWAY

RIGHT OF WAY / COMMON ACCESS

EXCLUSIVE DRIVEWAY

RIGHT OF WAY / COMMON ACCESS

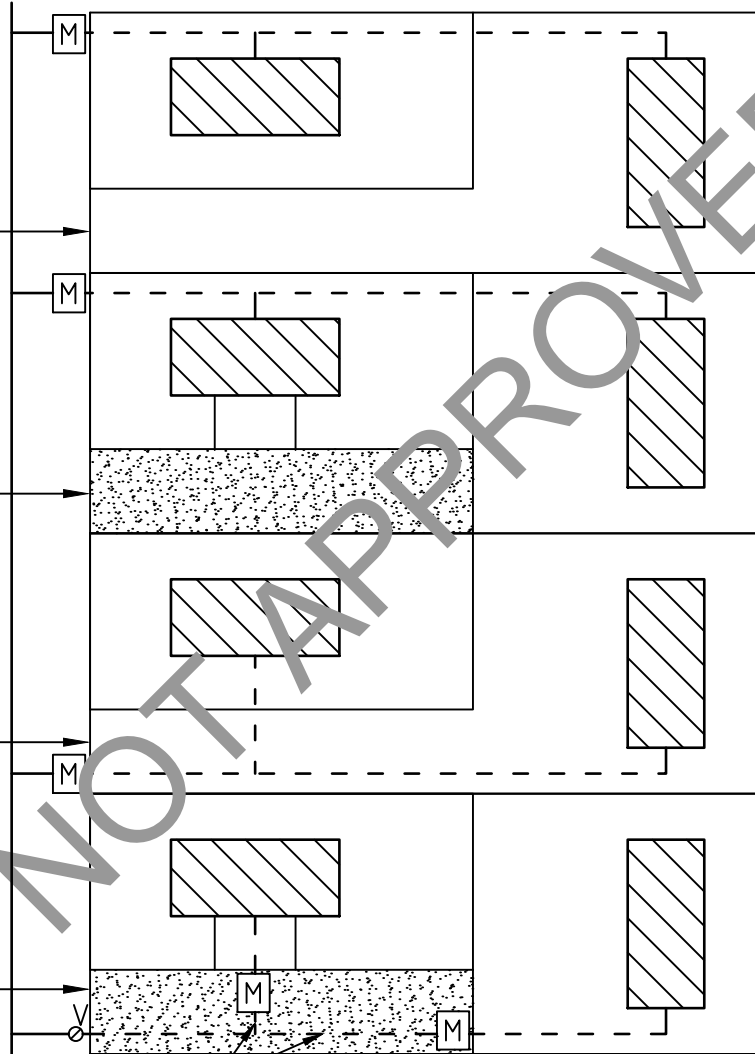

NOT COUNCIL RESPONSIBILITY

M DENOTES POSITION OF WATER METER ASSEMBLY

V DENOTES POSITION OF VALVE ASSEMBLY

--- PRIVATE

— COUNCIL OWNED

NELSON CITY COUNCIL

GROUP MANAGER INFRASTRUCTURE, NELSON

WATER CONNECTIONS
SUBDIVISION, CROSS LEASE & R.O.W.

TASMAN DISTRICT COUNCIL

ENGINEERING SERVICES MANAGER, TASMAN

DATE

01/07/19

NELSON - TASMAN
LAND DEVELOPMENT MANUAL

701

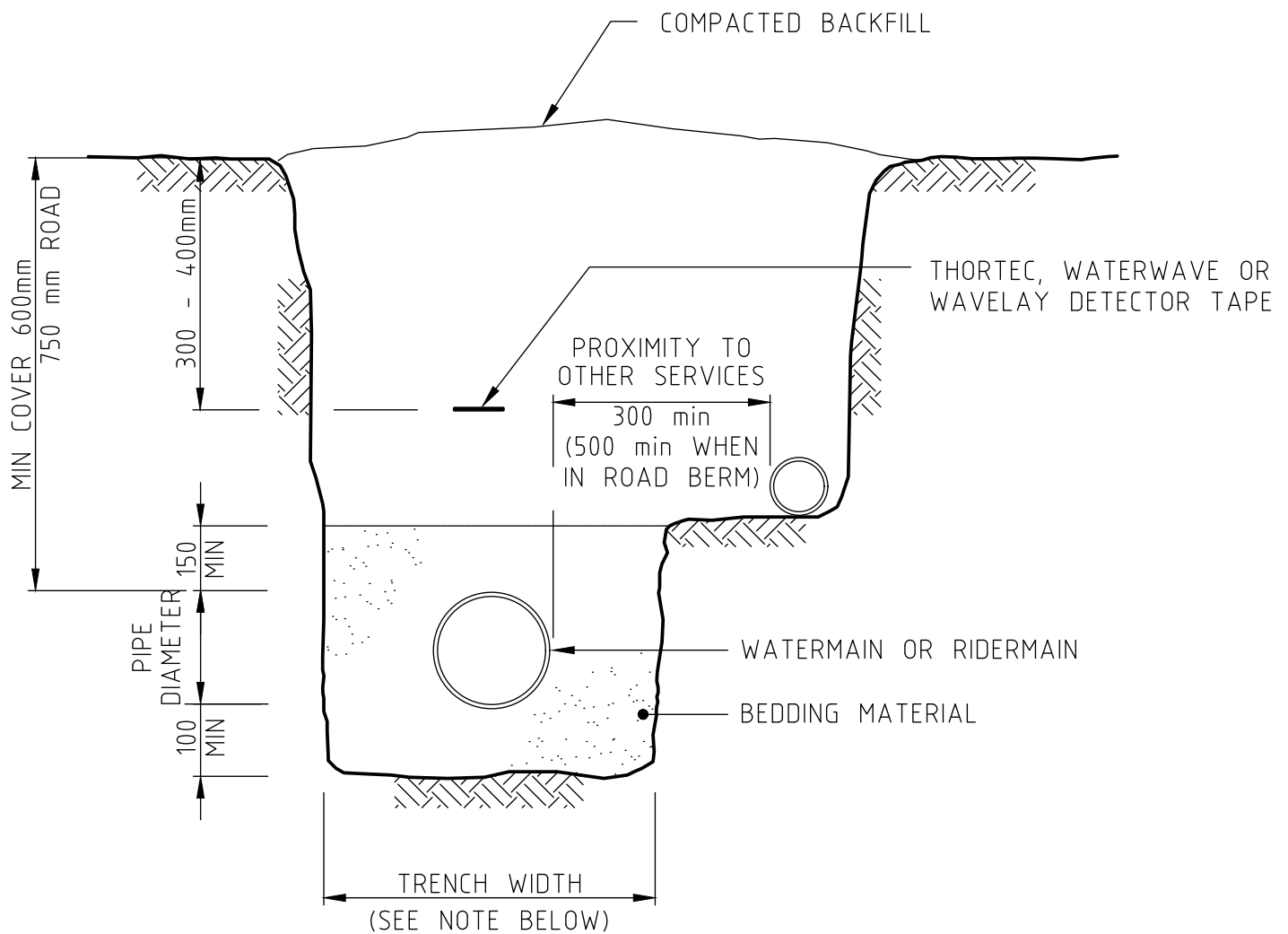

NOTES:

1. SEE DRAWING 614 FOR TRENCH WIDTHS
2. THE TRENCH WIDTH SHALL BE THE MINIMUM NECESSARY TO ADEQUATELY AND SAFELY LAY THE PIPE AND TO COMPACT THE SIDE SUPPORT ZONE

<p>NELSON CITY COUNCIL</p> <p><i>[Signature]</i></p> <p>GROUP MANAGER INFRASTRUCTURE, NELSON</p>		<p>WATER SHARED TRENCH CLEARANCES</p>	
<p>TASMAN DISTRICT COUNCIL</p> <p><i>[Signature]</i></p> <p>ENGINEERING SERVICES MANAGER, TASMAN</p>	<p>DATE</p> <p>01/07/19</p>	<p>NELSON - TASMAN LAND DEVELOPMENT MANUAL</p>	<p>702</p>



IN TRAFFIC LOADED AREAS/CARRIGEWAYS
INSTALL 200x200 CONCRETE SURROUND
27.5MPa WITH D10 HOOP

IN BERM AREAS INSTALL 150x150
CONCRETE SURROUND

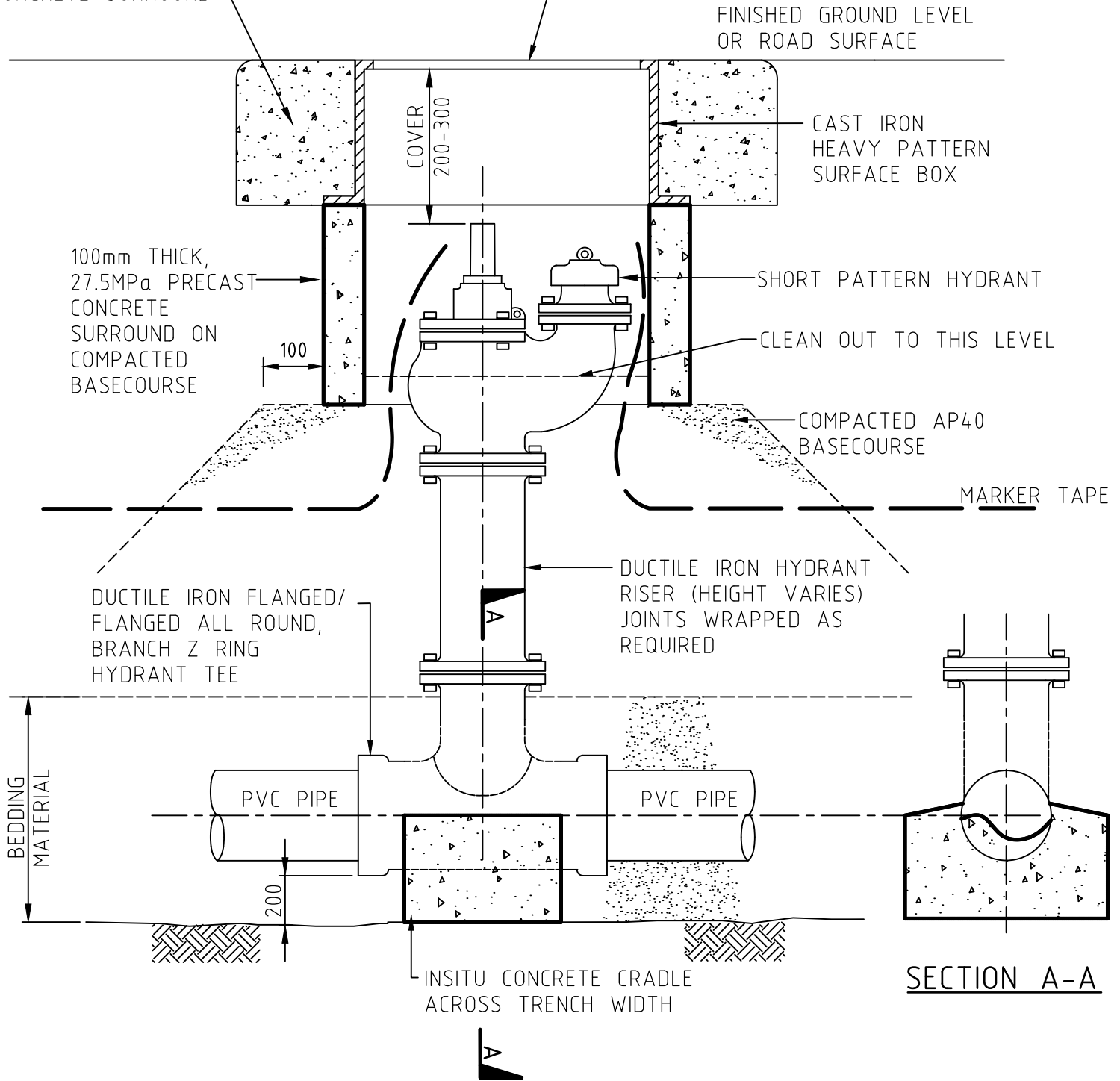
HYDRANT BOXES SHALL BE EMBOSSED
WITH 'FH' ON TOP OF COVER. COVER &
FRAME SHALL BE TO CLASS C STRENGTH
IN BERM ACCESS OR CLASS D IF IN
TRAFFIC LOADED AREAS, TO AS3996.
COVER MUST BE ANTI-ROCKING

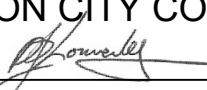

FLANGED TEE ANCHOR - REFER TO
DRAWING 704: SLUICE VALVE INSTALLATION

NELSON CITY COUNCIL  GROUP MANAGER INFRASTRUCTURE, NELSON		FIRE HYDRANT INSTALLATION Z RING JOINTED	
TASMAN DISTRICT COUNCIL  ENGINEERING SERVICES MANAGER, TASMAN	DATE 01/07/19	NELSON - TASMAN LAND DEVELOPMENT MANUAL	703

IN TRAFFIC LOADED AREAS/CARRIGEWAYS
 INSTALL 200x200 CONCRETE SURROUND
 27.5mPa WITH D10 HOOP

IN GRASSED OR VEGETATED AREAS
 INSTALL 150x150 CONCRETE SURROUND

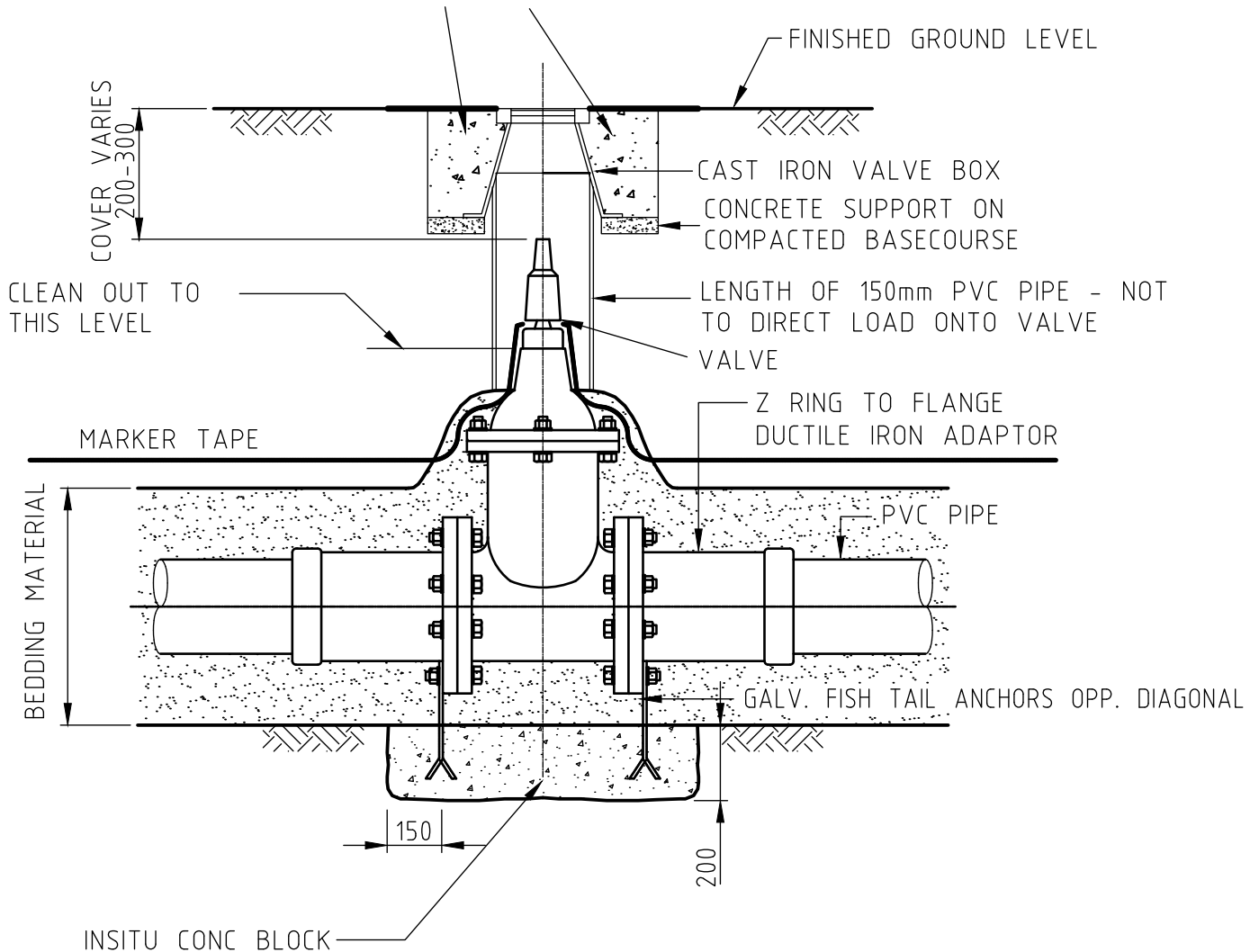

NELSON CITY COUNCIL
[Signature]
 GROUP MANAGER INFRASTRUCTURE, NELSON

SLUICE VALVE INSTALLATION

TASMAN DISTRICT COUNCIL
[Signature]
 ENGINEERING SERVICES MANAGER, TASMAN

DATE
 01/07/19

NELSON - TASMAN
 LAND DEVELOPMENT MANUAL

704

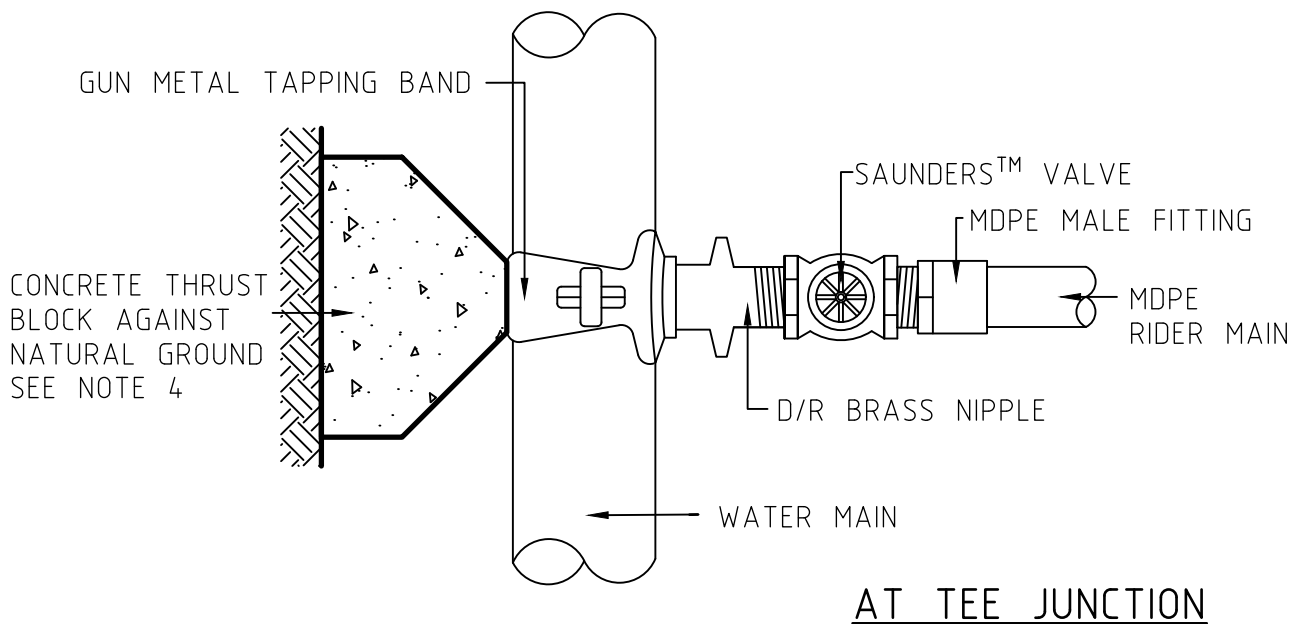
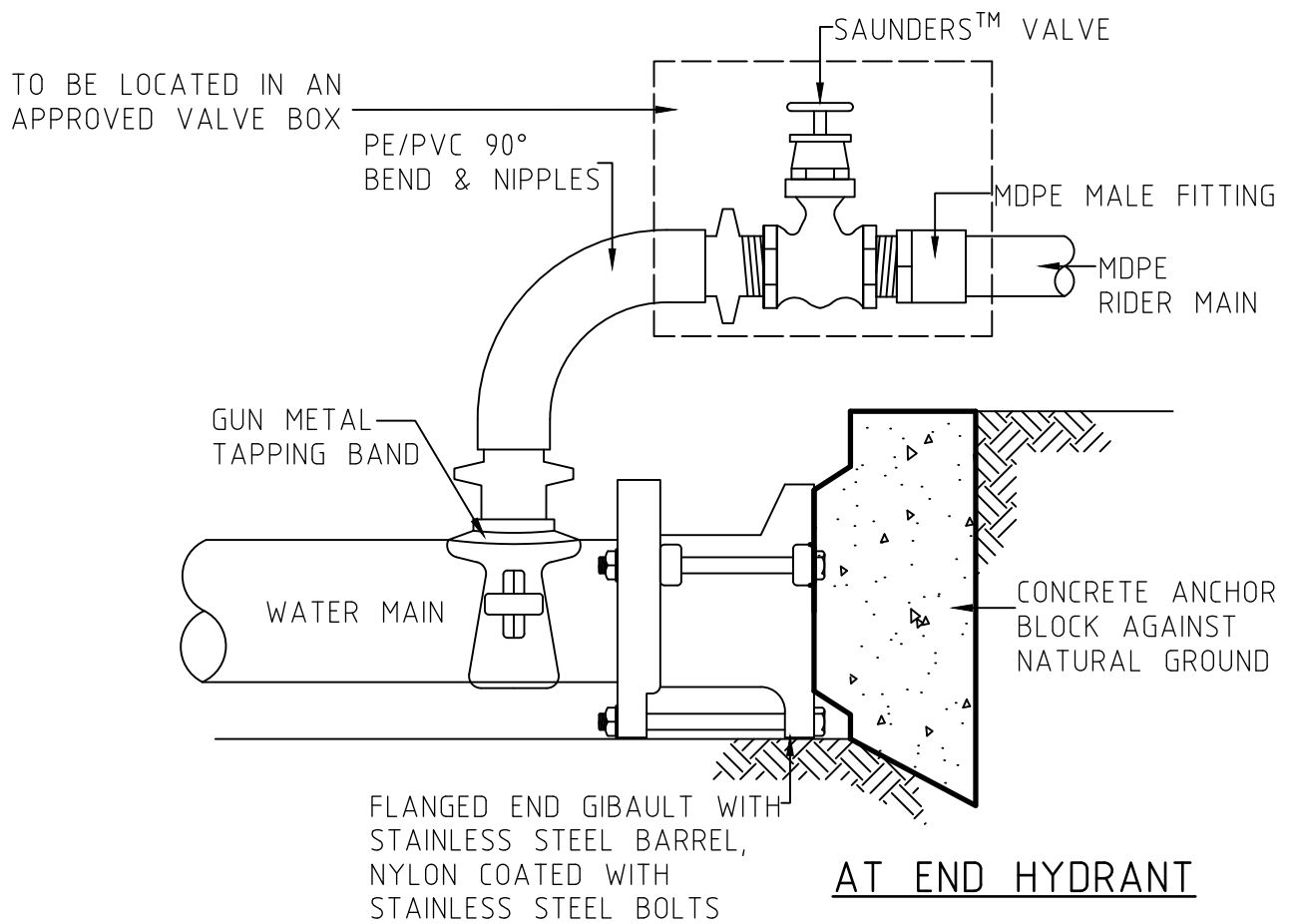

NOTES

1. ALL COMPONENTS TO BE COUNCIL APPROVED
2. THIS DIAGRAM APPLIES TO THE SITUATION WHERE THE MAIN IS LOCATED IN THE FOOTPATH OR BERM WHERE THE MAIN IS LOCATED IN THE ROAD THE LAYOUT SHALL BE MODIFIED SO THAT THE SAUNDERS™ VALVE IS LOCATED IN THE FOOTPATH OR BERM.
3. FOR 50mm ϕ RIDERMAINS A SLUICE VALVE IS REQUIRED and THEREFORE THE COPPER 'UPSTAND' SHALL BE OMITTED.
4. NO CONCRETE TO BE POURED AGAINST PIPE

NELSON CITY COUNCIL

[Signature]
GROUP MANAGER INFRASTRUCTURE, NELSON

TAPPING BAND RIDER MAIN CONNECTION

TASMAN DISTRICT COUNCIL

[Signature]
ENGINEERING SERVICES MANAGER, TASMAN

DATE

01/07/19

NELSON - TASMAN
LAND DEVELOPMENT MANUAL

705

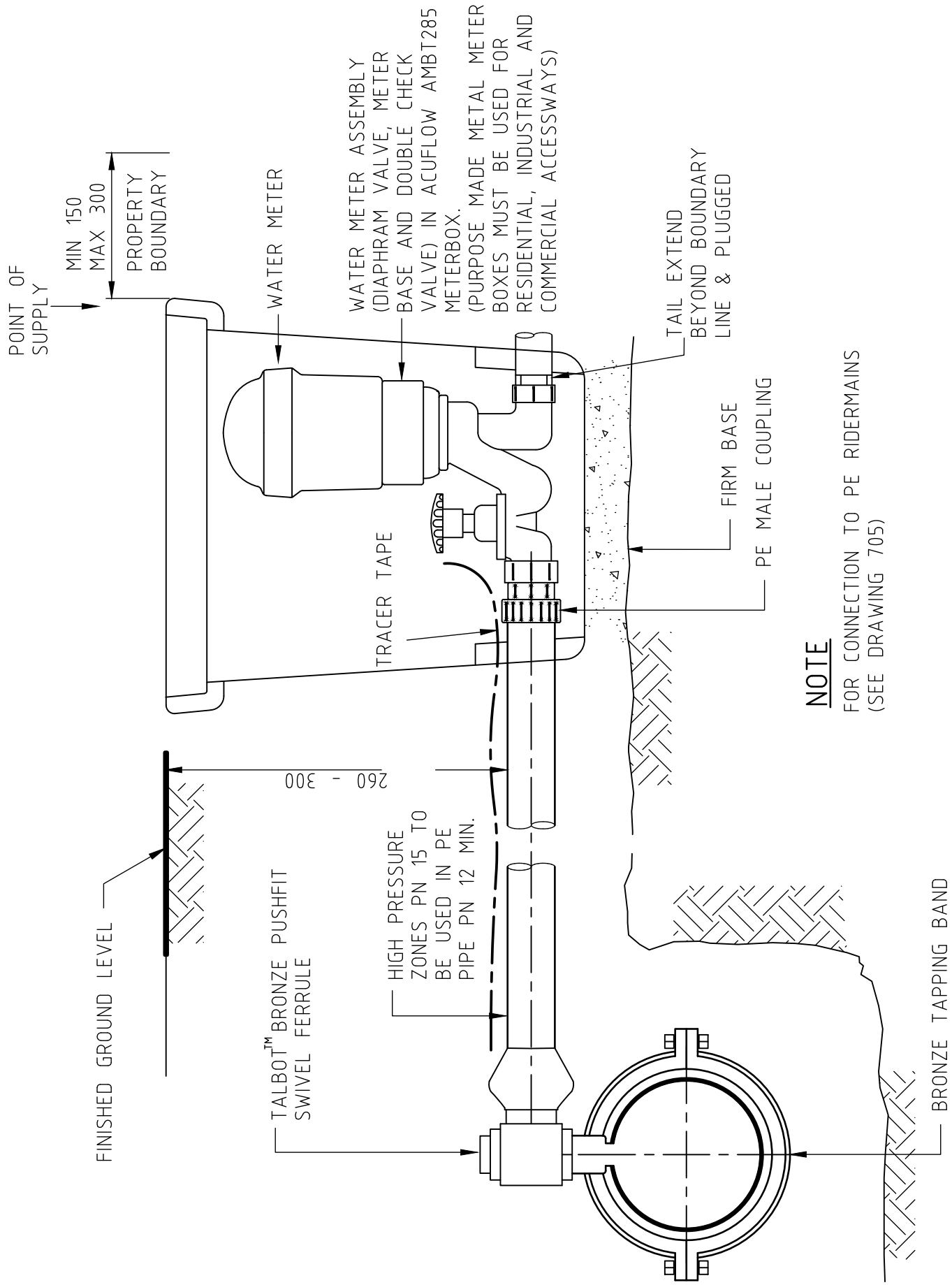

NELSON CITY COUNCIL

[Signature]
GROUP MANAGER INFRASTRUCTURE, NELSON

WATERMAIN LATERAL FOR
PROPERTY CONNECTION

TASMAN DISTRICT COUNCIL

[Signature]
ENGINEERING SERVICES MANAGER, TASMAN

DATE

01/07/19

NELSON - TASMAN
LAND DEVELOPMENT MANUAL

706

FLANGES FOR PIPES, VALVES & FITTINGS TO AS-2129

SURFACE PREPARATION

WIRE BRUSH LOOSE DIRT AND RUST FROM THE FLANGE AND ADJACENT PIPE, IF APPROPRIATE AND 100mm ONTO ANY SHOP COATING. ENSURE ALL SURFACES ARE CLEAN. DENSO PRIMER CAN BE APPLIED TO MOIST OR DAMP SURFACES, BUT VERY WET SURFACES SHOULD BE DRIED

PRIMING

APPLY DENSO PRIMER TO ALL METAL SURFACES WHERE POSSIBLE, PROTECT NUTS AND BOLTS BY DIPPING IN DENSO PRIMER BEFORE ASSEMBLY

FILLING

FLANGES TO TABLES A & D MOULD DENSO MASTIC OVER THE HEADS OF BOLTS, NUTS AND SCREW THREADS WITH A MINIMUM COVERAGE OF 5mm TAPER ONTO FLANGE FACE TO PROVIDE A SUITABLE CONTOUR FOR TAPE WRAPPING FLANGES TO TABLES E DUE TO THE INCREASED NUMBER OF BOLTS IN THIS CASE, IT IS NECESSARY TO USE DENSO MASTIC BETWEEN INDIVIDUAL BOLTS AND NUTS TO PROVIDE A SUITABLE CONTOUR FOR TAPING

WRAPPING

APPLY ONE COMPLETE TURN OF DENSO TAPE CIRCUMFERENTIALLY AROUND FLANGE WITH ONE SIDE AGAINST THE EDGE OF THE THE FLANGE. OVERLAP ABOUT 80mm. MOULD THE OVERHANGING TAPE OVER THE MASTIC. APPLY A SECOND TURN OF TAPE TO PROVIDE A DOUBLE THICKNESS AROUND THE FLANGE AND COVER THE OPPOSITE SIDE FOR FLANGES ON SHOP COATED LINES, SPIRALLY WRAP DENSO TAPE FROM THE PROTECTED FLANGE AND 100mm ONTO THE SHOP COATING ON EITHER SIDE.

OVERWRAPPING

ENVELOPE WITH DENSO MP/HD TAPE

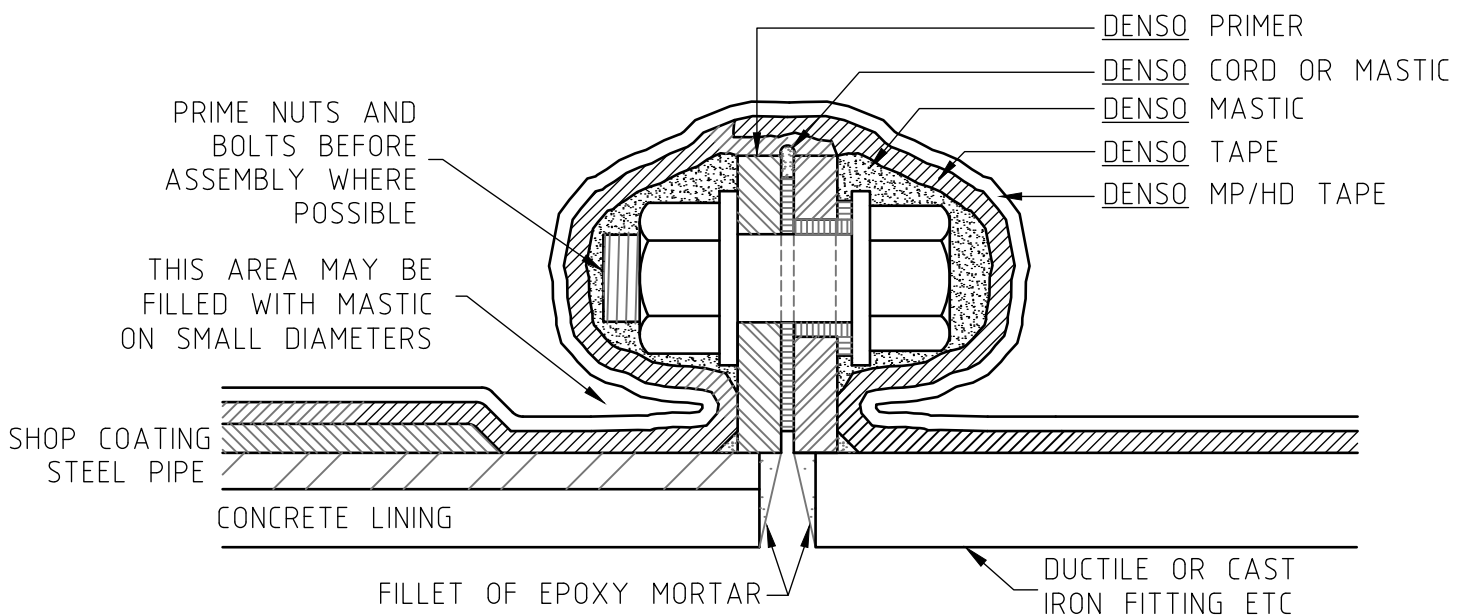

NELSON CITY COUNCIL

GROUP MANAGER INFRASTRUCTURE, NELSON

TASMAN DISTRICT COUNCIL

ENGINEERING SERVICES MANAGER, TASMAN

DATE

01/07/19

CORROSION PROTECTION
FOR FLANGES

NELSON - TASMAN
LAND DEVELOPMENT MANUAL

707

ALL UNRESTRAINED MECHANICAL COUPLINGS SHALL BE WRAPPED AS DETAILED BELOW WHERE MATERIALS OTHER THAT 316 STAINLESS STEEL AND COATINGS TO AS/NZS 4158 ARE USED.

SURFACE PREPARATION

WIRE BRUSH LOOSE DIRT AND LOOSE RUST FROM THE JOINT AND ADJACENT PIPE.
DENSO PRIMER CAN BE APPLIED TO MOIST OR DAMP SURFACES, BUT VERY WET SURFACES SHOULD BE DRIED

PRIMING

APPLY DENSO PRIMER TO ALL METAL SURFACES
 WHERE POSSIBLE, PROTECT NUTS AND BOLTS BY DIPPING IN DENSO PRIMER BEFORE ASSEMBLY

FILLING

FILL BETWEEN BOLTS AND SLEEVE, AND BOLTS TO TOP FLANGES WITH DENSO MASTIC
 COVER BOLT HEADS, NUTS AND ANY PROTRUDING THREAD WITH DENSO MASTIC

WRAPPING

WHERE A SERVICE TAPPING MAY BE INCLUDED WITH THE UNRESTRAINED MECHANICAL COUPLING, APPLY ONE COMPLETE TURN OF DENSO TAPE AROUND THE JOINT LAPPING BOTH ENDS ONTO THE SERVICE PIPE.
 APPLY DENSO TAPE AROUND ONE END OF JOINT WITH AN END LAP OF 80mm. MOULD THE TAPE FROM THE HIGHEST POINT ON THE FLANGE WORKING DOWN TO EXCLUDE AIR BUBBLES.
 APPLY ANOTHER COMPLETE TURN OF TAPE SIMILARLY WITH MINIMUM SIDE LAP OF 20mm. MOULD THE TAPE AROUND THE MASTIC COVERED BOLT HEADS, E.T.C.



OVERWRAPPING

ENVELOPE WITH DENSO MP/HD TAPE

NOTE

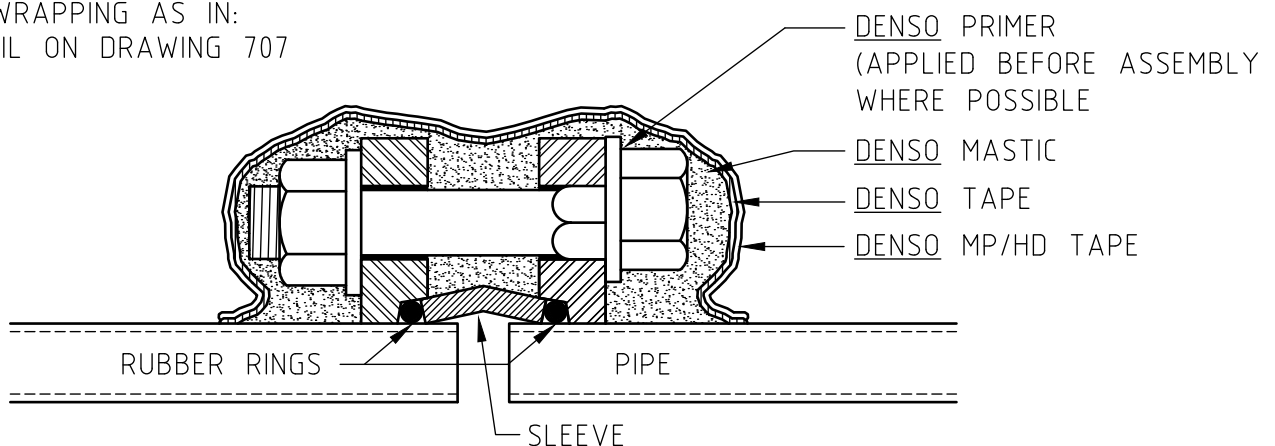
FOR CONCRETE LINED STEEL PIPES
DENSO SYSTEM TO OVERLAP
 ONTO SHOP WRAPPING AS IN:
 FLANGE DETAIL ON DRAWING 707

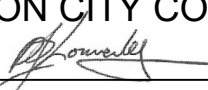

NELSON CITY COUNCIL  GROUP MANAGER INFRASTRUCTURE, NELSON		CORROSION PROTECTION FOR UNRESTRAINED MECHANICAL COUPLINGS	
TASMAN DISTRICT COUNCIL  ENGINEERING SERVICES MANAGER, TASMAN	DATE 01/07/19	NELSON - TASMAN LAND DEVELOPMENT MANUAL	708

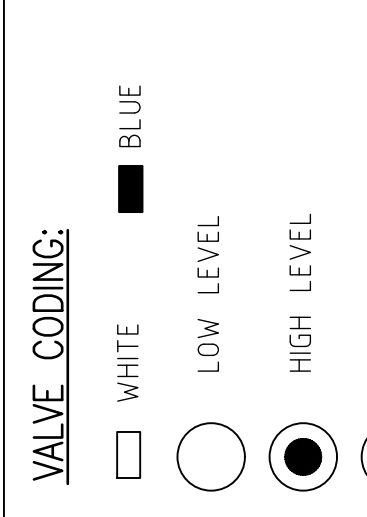

VALVE CODING:

- WHITE
- BLACK
- LOW LEVEL
- HIGH LEVEL
- SHUT
- BYPASS
- AIR VALVE
- SCOUR VALVE
- PUMPED SUPPLY (EXTRA HIGH LEVEL)

NOTES

1. PAINT USED FOR ALL ROAD MARKINGS SHALL BE NZTA M07 "ROAD MARKING PAINT" COLOUR AS ABOVE.
2. ALL HYDRANT KERB MARKINGS SHALL BE YELLOW AND ALL VALVE KERB MARKINGS SHALL BE BLUE.

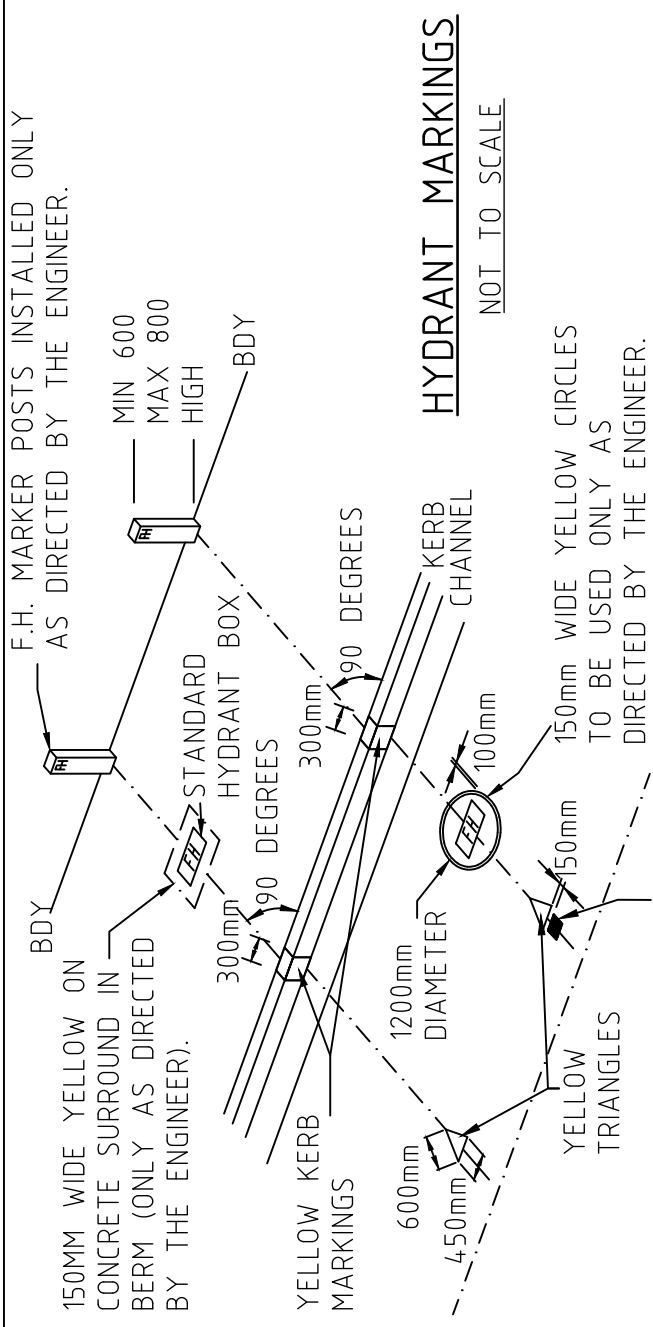

HYDRANT MARKINGS

NOT TO SCALE

150mm WIDE YELLOW CIRCLES TO BE USED ONLY AS DIRECTED BY THE ENGINEER.

BLUE RAISED REFLECTIVE PAVEMENT MARKER AT OR CLOSE TO, AND ON THE APPROPRIATE SIDE OF, THE CENTRE OF THE ROADWAY AT OR NEAR THE BASE OF THE YELLOW TRIANGLE MARKER.

S.V. MARKER POSTS INSTALLED ONLY AS DIRECTED BY THE ENGINEER.

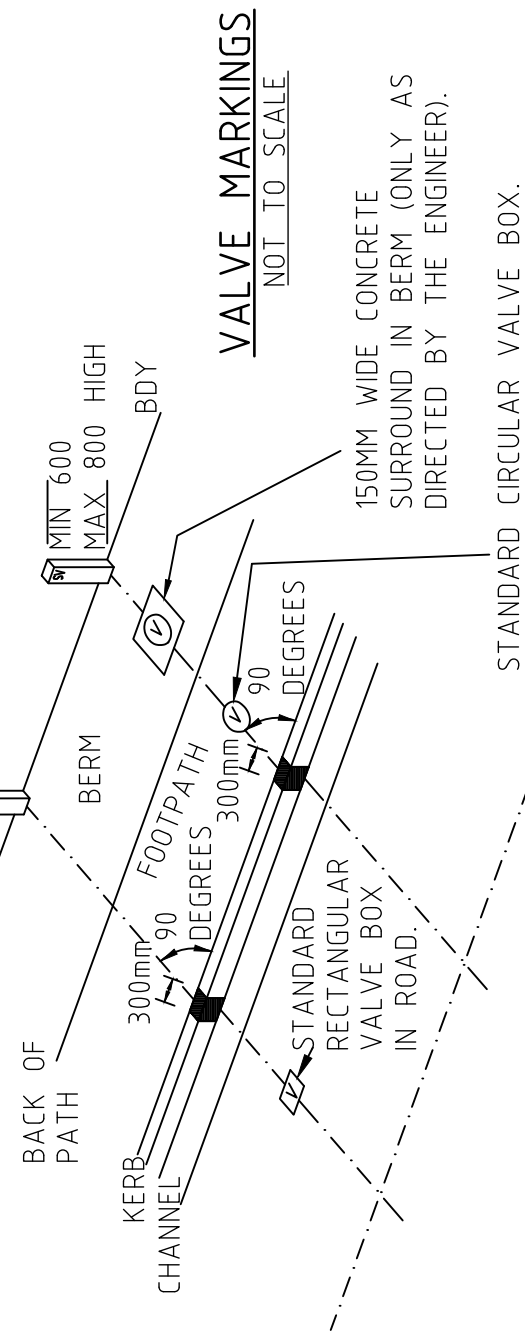

VALVE MARKINGS

NOT TO SCALE

150MM WIDE CONCRETE SURROUND IN BERM (ONLY AS DIRECTED BY THE ENGINEER).

STANDARD CIRCULAR VALVE BOX.

NELSON CITY COUNCIL
 GROUP MANAGER INFRASTRUCTURE, NELSON

TASMAN DISTRICT COUNCIL
 ENGINEERING SERVICES MANAGER, TASMAN

VALVE AND HYDRANT ROAD MARKINGS

DATE
 01/07/19

NELSON - TASMAN
 LAND DEVELOPMENT MANUAL